

**15-70 Amperes
Two/Three-phase
Zero-fired**

SCR POWER CONTROLLER

Instruction, Operation and Maintenance Manual

Number: 9100039
Revision 3

AMETEK[®]
HDR POWER SYSTEMS

**530 Lakeview Plaza Blvd, Ste C
Worthington, Ohio, USA 43085**
Toll Free: 1-888-PWR-CNTL (797-2685)
Phone: 614-308-5500
Fax: 614-308-5506
Web: www.hdrpower.com

This manual applies to all Model ZF2 and ZF3 SSR Power Controls. Former ZF2/ZF3 manual – 9100028 has been replaced with this manual.

For the support representative nearest you, please call Ametek HDR Power Systems main office at (614)-308-5500.

Revision 1	September 2014	Initial Release
Revision 2	July 2015	Revised Address
Revision 3	Aug 2022	General Revision

TABLE OF CONTENTS

IMPORTANT SAFETY INSTRUCTIONS	1
CHAPTER 1 - DESCRIPTION.....	3
1.1 General Description	3
1.2 Application	3
1.3 Specification	3
1.4 Option NO/NC (Thermostat)	3
1.5 Option FK (Fuse Kit)	3
1.6 Option TX (24 Vac Transformer)	3
1.7 Option UB (Load Unbalance Alarm)	4
1.8 Option SF (SCR Failure Alarm)	4
CHAPTER 2 - INSTALLATION	5
2.1 Mounting the ZF2/ZF3	5
2.2 Load Wiring	5
2.3 Line Wiring	5
2.4 Wiring Input Fuse	6
2.5 Command Signal Input	6
2.6 Heatsink Thermostat Contacts	6
CHAPTER 3 - OPERATION	7
3.1 General	7
3.2 Command Indicator	7
3.3 Command Input Control	7
CHAPTER 4 – TROUBLESHOOTING	9
4.1 Customer-Service Program	9
4.2 Troubleshooting Typical Symptoms	9
4.3 Static Precautions when Servicing	9
4.4 Environmental Problems	10
4.5 Input Power and Load Connections	10
4.6 Correcting Troubles in the ZF2/ZF3 Itself	11
CHAPTER 5 - SERVICE.....	13
5.1 Communication Procedures	13
5.2 Spare Parts Orders – Routine or Emergency	13
5.3 Spare Parts List	14
5.4 Drawing List	15
CHAPTER 6 – WARRANTY POLICY	17
6.1 Warranty	17
6.2 In-house Repair Services	17
APPENDIX.....	18
Appendix A – ZF2 System Schematic (-C models only)	18
Appendix B – ZF2 System Schematic	19
Appendix C – ZF3 System Schematic	20
Appendix D – ZF2 15-40 A Outline	21
Appendix E – ZF2 70 A Outline	22
Appendix F – ZF3 15-40 A Outline	23
Appendix G – ZF3 70 A Outline	24
Appendix H – Option Transformer Outline	25
Appendix I – Option FK Mounting	25

Appendix J – Declaration of Conformity

26

TABLES

Table 1.1 ZF2/ZF3 Model Number Breakdown	3
Table 1.2 General Specifications of ZF2/ZF3 SSR Models.....	4
Table 2.1 Control Transformer Voltage Wiring	5
Table 4.1 Troubleshooting Chart (Symptoms and Solutions)	11
Table 5.1 ZF2 SSR Spare Parts List	14
Table 5.2 ZF3 SSR Spare Parts List	14
Table 5.3 ZF2/ZF3 SSR Drawing List.....	15

IMPORTANT SAFETY INSTRUCTIONS



WARNING

Observe all warnings and cautions in this manual. Failure to do so may result in serious injury or death.

Refer all service to properly trained and qualified service personnel. Never work alone.

Lethal voltages exist on exposed heat sinks even if the power controller is turned off. Remove power and lock out power before attempting any service.

SAVE THESE INSTRUCTIONS

This manual contains important safety instructions that must be followed during the installation and maintenance of the SCR Power controller. Read this manual thoroughly before attempting to operate this Power controller.

An appropriate branch circuit fused disconnect or circuit breaker with this Power Controller is required to ensure the safety of operating personnel.



CAUTION

HAZARDOUS VOLTAGES exist at the Power Controller Line and Load terminals, **AT ALL TIMES**, when input voltage is connected. This condition exists even when the Power Controller is set to deliver zero output.

Printed circuit boards contain sensitive components that can be damaged by electrostatic discharge (ESD). Observe precautions for handling electrostatic sensitive devices. Reference Maintenance and Troubleshooting Chapter of this manual for details

In case of fire, use a dry chemical fire extinguisher to put out the fire. Using a liquid fire extinguisher may cause electric shock.

The SCR Power Controller makes use of components dangerous for the environment (electronic printed circuit boards, electronic components). The components removed must be taken to specialized collection and disposal centers.



E151547

100kA SCCR



IEC 947-5-1

CHAPTER 1 - Description

1.1 General Description

The ZF2 is three-phase 2-leg/4 SCR control and the ZF3 is a three-phase, 3-leg/6 zero-fired SCR Power Controller. Each of these can operate with a wide variety of input signals and line voltages up to 575 Vac and currents ranging from 15 through 70 amperes. The ZF1's output voltage is proportional to its input signal. HDR's zero-fired SCR Power Controls utilize a variable-time-base that helps maintain constant power to the load. The ZF1 SSR Series utilizes an isolated base Solid-State-Relay (SSR) Module which contains two SCRs connected back to back. The firing circuit is based on a common phase firing integrated circuit which includes soft-start for loads which have a large resistance change due to temperature or start-up. Terminals are provided to ease installation.

1.2 Application

A variable time base firing circuit is used to provide precise control of power to resistive loads. These units should never be used on inductive loads. However, they are versatile enough to be used in place of mechanical contactors and mercury relays on dryers, kilns, ovens, environmental chambers, extruders, molding equipment, and other types of equipment which uses resistive heat.

1.3 Specification

Specifications for the ZF2/ZF3 SSR power controller are given in Tables 1.1 and 1.2.

Table 1.1 ZF2/ZF3 Model Number Breakdown

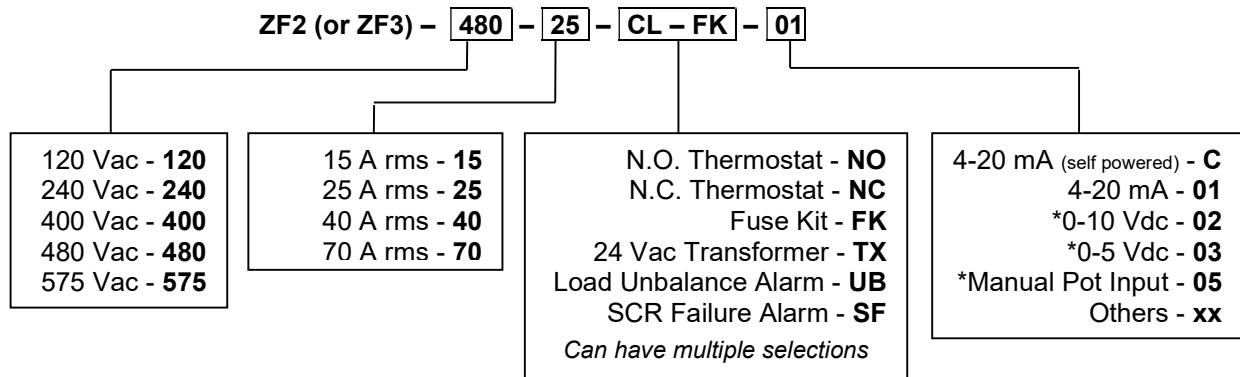

NOTE: * Requires 24 Vac Transformer Option

1.4 Option NO/NC (Thermostat)

Heatsink Thermostats (Option NO or NC) provide a dry contact either Normally Open (NO) or Normally Closed (NC).

1.5 Option FK (Fuse Kit)

The Fuse Kit (Option FK) consists of a Semi-Conductor Fuse and a fuse block. It is the user's responsibility to mount this fuse kit and connect in series with the Line of the Power Controller.

1.6 Option TX (24 Vac Transformer)

The ZF1 requires 24 Vac @ 3VA control power for Voltage or Pot Command signal. Appropriate sized transformer (Option TX) is available with 120, 240, 400, 480 or 600 Vac primaries.

Table 1.2 General Specifications of ZF2/ZF3 SSR Models

Input line voltage: *	120, 240, 400, 480, or 575 Vac, +10%, -15% , Two-phase or Three-Phase				
Line frequency:	50 or 60 Hz				
Current rating: *	As indicated by model number (refer to Table 1.1)				
Thermostat contact rating:	120 Vac, 5 A; resistive (optional)				
Input Signal:					
Voltage	0 to 1.5 V (min); 0 to 10 V (max)				
Current	0 to 6 mA (min); 0 to 20 mA (max)				
Control methods:	1. Potentiometer, 5 k Ω , 1/2 watt (Customer-supplied). 2. Temperature or process controller *				
Control signal input impedance:					
Voltage input	1500 Ω				
Current input	500 Ω				
Isolation:					
From power to ground	1,500 Vac				
Power SCRs protection:					
Current surge	Subcycle I ² T semiconductor fuse - OPTIONAL				
Transient voltage spikes (dv/dt)	Metal Oxide Varistor (MOV) across each SCR pair				
SCCR Rating	100kA				
Miscellaneous:					
Zero-firing timebase	Variable see 3.1				
Controls:	ZERO and SPAN potentiometers; 10-turn, screwdriver-adjustable.				
Approvals	UL/cUL (E151547), CE				
Ambient Temperature range:					
Environment	32 °F to 122 °F (0 °C to 50 °C) surrounding air Pollution degree 2 Overvoltage Category III				
Storage	14 °F to 158 °F (-10 °C to 70 °C)				
Weight per unit	Current Rating	lbs	kg	lbs	kg
:	15 through 40 A	2.5 lbs	1.1	3.6	1.63
	70 A	5.7 lbs	2.6	9	4.1
Outline and mounting:	See appropriate drawing in Appendix				

* Specify with order

NOTE: The ZF2/ZF3 should be tested or operated with an adequate load since an open output will have line voltage at the load connections.

1.7 Option UB (Load Unbalance Alarm)

The Load Unbalance Alarm Option (UB) monitors three phase currents and provides an alarm if the load currents become unbalanced by more than the preset percentage. The limit is DIP switch selectable and a form C relay is available for alarm along with diagnostic indicators. This option is mounted external to ZF2/ZF3 Power Controller, reference 3-phase Load Unbalance & Shorted SCR Alarm manual.

1.8 Option SF (SCR Failure Alarm)

The SCR Failure Alarm Option (SF) optional circuit monitors each SCR pair's voltage drop and detects when an SCR is shorted. Three green LEDs are lit when the SCRs are not shorted. If an SCR shorts, the respective green LED will go out and the red alarm LED will light and the Form C relay will energize. Relay output and terminals for connection are provided. This option is mounted external to ZF2/3 Power Controller, reference 3-phase Load Unbalance & Shorted SCR Alarm manual.

CHAPTER 2 - Installation

2.1 Mounting the ZF2/ZF3

Determine space and mounting hole requirements by referring to the outline drawing (in the Appendix) that applies to your model's current rating. Mount the unit so the line and load connections are at the top and ensure that upward airflow over the heat sink fins is unrestricted.

2.2 Load Wiring

Connect the load to the proper terminals (refer to the input/output connections schematic in Appendix A) using appropriately sized and insulated conductors. All input/output conductors should be stranded copper wire only; minimum temperature rating is 75 °C.



WARNING - ELECTRIC SHOCK CAN KILL

HAZARDOUS VOLTAGES exist at the (**LINE and LOAD**) terminals when the input voltage is connected. This condition exists even when the Controller is set to deliver zero output. Always remove power and properly lock out power to the unit before attempting any service, including the load.

2.3 Line Wiring

Connect input lines from the fused disconnect or circuit breaker to the Line terminal (refer to the input/output connections diagram) using appropriately sized and insulated conductors. (**NOTE:** Input power should be routed through a fused disconnect or circuit breaker with a fuse or trip rating of 100% to 125% of the current rating stamped on the nameplate of the ZF2 or ZF3 series unit.) Torque Line and Load connection to 45 in-lbs.



WARNING

Branch circuit overcurrent protection required is to be provided in accordance with the national and local codes of the inspecting authority.

If required, mount and connect the Control transformer (Option TX) per the schematic in Appendix A. Select the appropriate Transformer voltage tap as shown in Table 2.1 and solder wires to the primary terminals. An insulator is also provided to install between the transformer and the mounting plate.

Table 2.1 Control Transformer Voltage Wiring

Desired Voltage	Primary Tap
120	120
208	240
220	240
240	240
380	400
400	400
415	400
480	480
575	575

2.4 Wiring Input Fuse

An Option (FK) Fuse Kit is available with high speed fuses (I^2T) to protect the Solidstate Relays (SSR) from Load shorts. The fuses are **NOT** meant for over current protection, separate branch circuit protection is required. Mount the fuse blocks, reference Appendix G for mounting details.

2.5 Command Signal Input

HDR's ZF2/ZF3 SSR Power Controllers have the capability of having a current, voltage or potentiometer Command Signal input. On -C models it is current control only. If the Firing board is capable of both voltage and current there is a 500 ohm 1/4W resistor is connected across terminals 1 and 2, for voltage command and remote potentiometer the 500 ohm resistor is removed. For Remote control a potentiometer may be located on a remote panel near other controls related to the process being powered by the ZF2/ZF3. The potentiometer should be rated 5 k Ω , 1/2 Watt minimum. Reference the schematic in Appendix A.

The Command Signal is **NOT** isolated from the Line. An isolated device such as an isolated PLC output module to drive the command signal is required or damage can occur to the Power Controller.

2.6 Heatsink Thermostat Contacts

Normally-open (N.O.) or normally-closed (N.C.) thermostat is mounted to the heat sink when this option is purchased. This thermostat, which close or open on high heat sink temperature (200 °F), may be used to initiate an alarm, shunt trip, or other device for SCR protection.

CHAPTER 3 - Operation

3.1 General

The ZF2/ZF3 controls power by the switching action of two SCRs connected in a back to back configuration in each controlled phase. The zero crossing detector built into the solid-state relay module synchronizes the gating of these SCRs with the line frequency (either 50 or 60 Hz). The firing circuit provides timing pulses to the SSR proportional to the command signal. The power controller regulates the output voltage by proportionally controlling the number of AC cycles “on” versus the number “off”. Because the voltage is “turned on” at zero crossing, very little radio frequency interference (RFI) is generated and the power factor (PF) is near unity. The output may be adjusted by a voltage or current signal from a process controller. Zero and Span controls allow the user to calibrate the power controller’s output to the process signal.

The firing control circuit of the ZF2/ZF3 operates on a variable rather than fixed time base. Operating on a fixed-time base of 1/3 second (20 cycles), for example, at 50% power the SCRs would be on for 10 cycles, off for 10 cycles, on for 10 cycles, and so on. Operating on a variable-time-base, at 50% power, the SCRs are on for one cycle and off for the next. At 75% power, the controller, with a fixed-time-base of one-third second (20 cycles), would be on for 15 cycles and off for 5. The variable-time-base, however, would be on for three cycles, off for one, and so on. The time required to describe the operation of the ZF1 would be the period of four cycles in this case – three cycles on and one cycle off.

For 50% power, the time required to describe the operation of the variable-time-base would be the period of two cycles – one cycle on and one cycle off. Hence the time-base of the ZF1 would be the period of two cycles for 50% power and four cycles for 75% power. The time-base varies for other power levels as well, so its period is always that of a whole number of cycles

Keep in mind that ZF units can only be used on resistive loads. If an inductive load or a load with a large resistance change (instantaneously or cold to hot) is being used, a phase fired (PF) power control should be used.

3.2 Command Indicator

The Command Indicator is a green Light Emitting Diode (LED) located on the Firing board. The brilliance of this LED will change with a Command Signal. The flash rate increases with an increased Command Signal and decreases with a decreased Command Signal

3.3 Command Input Control

Connect the control signal per the schematic in Appendix A. The ZF2/ZF3 Zero and Span is calibrated at the Factory for the specified input type and normally does **NOT** need adjustment. However, should a setup be required use the following methods. (Note: Adjustments requires a jeweler’s screw driver for multi-turn bias & gain adjustments.)

The output voltage linearity for any given command is affected by the setting of the Zero and Span adjustments.

- a. Set the **ZERO** and **SPAN** controls fully CCW (counterclockwise).
- b. Connect a voltmeter across terminals LINE and LOAD of the ZF2/ZF3. Set the voltmeter range to measure full input voltage.
- c. Close the fused disconnect or circuit breaker to apply power to the ZF2/ZF3. Turn the Process controller on and set to demand zero power output or remote potentiometer fully CCW.
- d. Adjust the **ZERO** control CW until the output just turns on, then turn the **ZERO** control CCW just to the point where the output voltage reading is zero.

- e. Set the Process controller to demand 100% output or the remote potentiometer fully CW. Observing the voltmeter, adjust **SPAN** CW just to the point where the reading is below the maximum output voltage. Then adjust **SPAN** CW just to the point where the meter reading is at maximum.

Note: The output voltage measurement on Zero Fired Power Controllers with a digital voltmeter will be erratic except at full output. This is due to the variable pulses to regulate the output.

- f. Repeat steps 3.3c through 3.3e as necessary, to ensure proper control adjustments have been made.
- g. Turn off the line power to the ZF2/ZF3 and disconnect the test equipment. The ZF2/ZF3 is now ready for operation.

CHAPTER 4 – Troubleshooting

4.1 Customer-Service Program

Although service is seldom necessary, because of the inherent long-term reliability of solid-state components and conservative design, Ametek HDR Power Systems emphasizes customer satisfaction by maintaining a rapid-response, cooperative customer-service. If operational difficulties occur, Ametek HDR Power Systems will provide replacement parts or units quickly, courteously and efficiently. If servicing problems arise that are not within the scope of the following troubleshooting guide, service is readily available, as detailed in Chapter 5.

4.2 Troubleshooting Typical Symptoms

The ZF2/ZF3 is considered to be operating properly when its output voltage can be satisfactorily varied from 0% to 97% of the available input voltage by a control signal. Improper operation of the unit is usually indicated by one of the following symptoms:

- a. No output.
- b. Full output at all times, with no change resulting from a control signal change.
- c. Output variable from some intermediate value to maximum, but cannot be brought to zero.
- d. Output variable from zero to some intermediate value, but cannot be brought to maximum.

The symptoms listed may be caused by one or more of the following: an environmental problem, faulty input-power or load connections, and the ZF2/ZF3 itself. These possible causes should be investigated as described in Chapters 4.4 through 4.6.



WARNING - ELECTRIC SHOCK CAN KILL
HAZARDOUS VOLTAGES exist at the exposed (LINE and LOAD) terminals unless the line-source fused disconnect or circuit breaker is open or off. This is true even when the SCR's are turned off. Always remove power and properly lock out power to the unit before attempting any service is performed.

4.3 Static Precautions when Servicing

Servicing should be performed by qualified personnel only, following procedures described herein.



ATTENTION
Printed circuit boards contain sensitive components that can be damaged by electrostatic discharge (ESD). Observe precautions for handling electrostatic sensitive devices.

If troubleshooting indicates a need to replace a component on a printed circuit board or possibly the entire board, measures to prevent electrostatic discharge (ESD) damage must be taken.

- a. ALWAYS wear a wrist strap connected to ground through a 1-megohm resistor when working on printed circuit boards.
- b. Use soldering iron with a grounded tip.
- c. Use a non-static solder sucker (metallic) or solder removal braid.

- d. Transport static sensitive components in static shielding bags or rails. A new printed circuit board should be treated as a static sensitive device. A part completely installed on a board does not make the part static-safe.
- e. If possible, perform printed circuit board maintenance at a work station that has a conductive covering which is grounded through a 1-megohm resistor. If a conductive table top is unavailable, a clean steel or aluminum table top is an excellent substitute.
- f. Keep plastic, vinyl, Styrofoam or other non-conductive materials away from printed circuit boards. They are good static generators that do not give up their charge easily.
- g. Return goods to Ametek HDR Power Systems in static-safe packaging. This will limit further component damage from ESD.
- h. CAUTION. Do not touch any printed circuit board unless you are wearing a ground wrist strap, as circuit damage may occur. Grounding kits are also available commercially and can be purchased through most electronic wholesalers.

4.4 Environmental Problems

Check to see that none of the following environmental problems exist.

Inadequate Cooling. Allow at least 1 inch of air space (in any direction) between the heat sinks and any item or structure near the ZF2/ZF3 power modules. Heat sink fins should be free of dust or dirt for proper heat transfer, and free of obstructions which could prevent proper airflow.

Contamination. The unit should be periodically cleaned of all dust and dirt. However, certain kinds of dust or particles are particularly conductive. A small accumulation of conductive material can cause component failures from arc-over or complete shorts.

High Ambient Temperature. Lack of a proper ambient-temperature check before installation, or an increase in ambient temperature, can result in numerous problems. Check the ambient temperature under existing conditions. If it is 122 °F (50 °C) or lower, ambient temperature should not be a problem. If it is above 122 °F (50 °C), steps should be taken to provide more cooling, or the ZF2/ZF3 should be moved to a cooler location, or call the Ametek HDR Power Systems service department.

Excessive Vibration. A significant degree of pitched or unpitched vibration can cause numerous problems. If vibration is isolated as a probable cause of improper operation, standard vibration-isolation mounting techniques should be employed.

4.5 Input Power and Load Connections

Turn off the power to the ZF2/ZF3 and check all power connections, input and output, to make sure they are mechanically secure and free of corrosion. Make the same checks at the power source and load. Visually check insulation on input and load wiring for evidence of damage or overheating.

4.6 Correcting Troubles in the ZF2/ZF3 Itself

Table 4.1 provides a comprehensive guide for troubleshooting the ZF2/ZF3.

Table 4.1 Troubleshooting Chart (Symptoms and Solutions)

Cause	Solution
No output even with manual control (Zero) turned full CW.	
(1a) Open SCR fuse	Disconnect power and check the fuse. If it has opened, replace it <u>after</u> completing (b)
(1b) SCRs not firing	Install a good fuse in the circuit, and apply power to the ZF2/ZF3. If the output is fully controllable using the manual control, then resume normal operation. If the power output is still zero, contact Ametek HDR Power Systems service.
Maximum power at all times regardless of control setting.	
(2a) All SCR networks shorted	Disconnect power and check the front-to-back SCR pairs by measuring resistance between terminals L1 (of the SSR) and X1. On the Rx1 scale, the resistance should be infinite in both directions. If a shorted component is indicated in any of these cases, replace it.
(2b) Firing control section defective	Return the power to the unit. If the problem persists, contact Ametek HDR Power Systems service.
Output is variable but can't be brought to zero with ZERO control	
(3a) SCR network shorted	Check SSR network per solution 2a.
(3b) Firing control section defective	Contact Ametek HDR Power Systems service for assistance
Output is variable but can't be brought to maximum with SPAN control	
(4a) Firing control section defective	Contact service for assistance

CHAPTER 5 - Service

5.1 Communication Procedures

If operational problems arise that cannot be resolved by review of all related procedures given in this manual, please contact "Service" at Ametek HDR Power Systems. Please have your model number and serial number of the unit ready as it is required for our technicians to assist you.

NORMAL BUSINESS HOURS 8 am to 5 pm, USA EASTERN TIME ZONE, Monday through Friday.

TELEPHONE 614-308-5500. Our Answering Service will accept your message during all off-hours, including weekends. We receive those messages at 8 am on the next normal workday. We will respond at the earliest time possible, within your time zone and normal work day.

FACSIMILE 614-308-5506. Automatic reception during all hours.

If you are experiencing downtime or other critical circumstances during our off-hours (see above), and wish to telephone us, please inform our Answering Service operator of the nature and degree of your problem. In such cases the operator is authorized to call Ametek HDR Power Systems Service. We cannot, however, guarantee that service assistance will be available at any given off-hour time.

When we are reached by phone, our first step will be to give you over-the-phone assistance at no charge. If the problem cannot be resolved by phone we will arrange for service at your site or by shipment to Ametek HDR Power System, as you request. We will make every possible attempt to support your emergency, on-site needs, regardless of how contacted.

5.2 Spare Parts Orders – Routine or Emergency

Requests for spare parts should be directed to "Inside Sales" at Ametek HDR Power Systems during normal hours, if possible, or via any method shown above for off-hours. Often we can provide same-day delivery for critical circumstances. When contacting us, please present as much information as possible – the related equipment Model Number and Serial Number; the required part name and any identifying part of vendor number(s); and your time needs. An approved Purchase Order Number should be given with your order.

5.3 Spare Parts List

The following table lists the minimum recommended quantities for spare parts for the ZF2/ZF3 SSR. As spares are used, replacements should be ordered.

Table 5.1 ZF2 SSR Spare Parts List

Item	Item No.	Qty
15 Ampere Units		
Fuse, 20 A, 700 V	7520070	1
PCB Assy, ZF2 Firing Circuit (-C Models only)	2081000	1
PCB Assy, ZF2 Firing Circuit	2082000	1
SSR, 50 A	7451110	1
MOV 660 V, 230 J	6600010	1
25 Ampere Units		
Fuse, 32 A, 700 V	7530070	1
PCB Assy, ZF2 Firing Circuit (-C Models only)	2081000	1
PCB Assy, ZF2 Firing Circuit	2082000	1
SSR, 50 A	7451110	1
MOV 660 V, 230 J	6600010	1
40 Ampere Units		
Fuse, 50 A, 700 V	7550070	1
PCB Assy, ZF2 Firing Circuit (-C Models only)	2081000	1
PCB Assy, ZF2 Firing Circuit	2082000	1
SSR, 90 A	7491110	1
MOV 660 V, 230 J	6600010	1
70 Ampere Units		
Fuse, 80 A, 700 V	7580070	1
PCB Assy, ZF2 Firing Circuit (-C Models only)	2081000	1
PCB Assy, ZF2 Firing Circuit	2082000	1
SSR, 90 A	7491110	1
MOV 660 V, 230 J	6600010	1

Table 5.2 ZF3 SSR Spare Parts List

Item	Item No.	Qty
15 Ampere Units		
Fuse, 20 A, 700 V	7520070	1
PCB Assy, ZF1 Firing Circuit	2099148	1
SSR, 50 A	7451110	1
MOV 660 V, 230 J	6600010	1
25 Ampere Units		
Fuse, 32 A, 700 V	7530070	1
PCB Assy, ZF1 Firing Circuit	2099148	1
SSR, 50 A	7451110	1
MOV 660 V, 230 J	6600010	1
40 Ampere Units		
Fuse, 50 A, 700 V	7520070	1
PCB Assy, ZF1 Firing Circuit	2099148	1
SSR, 90 A	7491110	1
MOV 660 V, 230 J	6600010	1
70 Ampere Units		
Fuse, 80 A, 700 V	7580070	1
PCB Assy, ZF1 Firing Circuit	2099148	1
SSR, 90 A	7491110	1
MOV 660 V, 230 J	6600010	1

5.4 Drawing List

This Chapter contains drawings that show outline dimensions, installation wiring, and printed circuit board component locations, as well as an overall schematic of the ZF2 and ZF3. These drawings are useful in installing and troubleshooting all ZF2/ZF3 models. Table 5.3 lists the drawings for each model, Appendix provides simplified drawings in the order of their appearance. Drawings may also be downloaded from www.hdrpower.com.

Table 5.3 ZF2/ZF3 SSR Drawing List

Drawing Title	Drawing No.
Schematic, ZF2 SSR (-C Models)	S2710017
Schematic, ZF2 SSR	S2710018
Schematic, ZF3 SSR	S2710034
Outline & Mounting, ZF2 SSR – 15 - 40 A (-C Models)	M2710017
Outline & Mounting, ZF2 SSR – 15 - 40 A	M2710018
Outline & Mounting, ZF2 SSR – 70 A (-C Model)	M2710081
Outline & Mounting, ZF2 SSR – 70 A	M2710082
Outline & Mounting, ZF3 SSR – 15 - 40 A	M2710034
Outline & Mounting, ZF3 SSR – 70 A	M2710083

CHAPTER 6 – Warranty Policy

This chapter details the warranty policy of Ametek HDR Power Systems products. Ametek HDR Power Systems standard warranty policy is listed below. Note that the warranty policy for a particular job agreement may be different from the standard policy. When in doubt about warranty information, consult the factory.

6.1 Warranty

WARRANTY

AMETEK HDR warrants that the equipment delivered will be free from defects in workmanship and material for a period of five years from the date of shipment. AMETEK HDR will repair or replace, at AMETEK HDR's option, any part found defective during proper and normal use, provided that written notice of the nature of the defect is received by AMETEK HDR within the five year warranty period and that the customer returns the part to AMETEK HDR freight paid both ways. This warranty is not transferable by the initial end user.

AMETEK HDR MAKES NO OTHER WARRANTIES, EXPRESSED OR IMPLIED (INCLUDING, WITHOUT LIMITATION, MERCHANTABILITY, FITNESS FOR PURPOSE, OR AGAINST INFRINGEMENT OF ANY PATENT) EXCEPT AS EXPRESSLY PROVIDED HEREIN.

THE REMEDY OF REPAIR OR REPLACEMENT IS CUSTOMER'S SOLE AND EXCLUSIVE REMEDY AND WILL SATISFY ALL OF AMETEK HDR'S LIABILITIES, WHETHER BASED ON CONTRACT, NEGLIGENCE, TORT, PRODUCT LIABILITY, STRICT LIABILITY, OR OTHERWISE. IN NO EVENT WILL AMETEK HDR BE LIABLE FOR INCIDENT OR CONSEQUENTIAL DAMAGES, NOR IN ANY EVENT SHALL HDR'S LIABILITY EXCEED THE UNIT PRICE OF ANY DEFECTIVE PRODUCT OR PART.

6.2 In-house Repair Services

For all repair service at Ametek HDR Power Systems, you will need a Repair Material Authorization (RMA) number. Call **(614) 308-5500** and request a Repair Material Authorization (RMA) number. Please reference this number when making inquiries. Use the shipping address below for returns:

Ametek HDR Power Systems
503 Lakeview Plaza Blvd, Ste C
Worthington, Ohio, 43085
Attention: Repair Department/RMA #()

Prepay the shipment and include the following information if you are not using an Ametek HDR Power Systems Return Repair Tag: the Repair Material Authorization (RMA) number, part number, a description of the problem, contact phone number, a technical contact phone number (if different) and any additional comments. Put the Repair Material Authorization (RMA) number on the label.

Warranty Repairs: In addition to securing Repair Material Authorization (RMA) number, please supply the **System Serial number** (found on the Power Controller).

Non-Warranty Repairs: Secure a Repair Material Authorization (RMA) number from Ametek HDR Power Systems. The price for exchange or repair will be quoted when the unit can be evaluated. Once determined a quote will be provide, please include your hard copy purchase order (PO) for this amount, or fax your PO directly to the Sales Department at (614) 308-5506. Expedited services are available upon request.

APPENDIX

Appendix A – ZF2 System Schematic (-C models only)

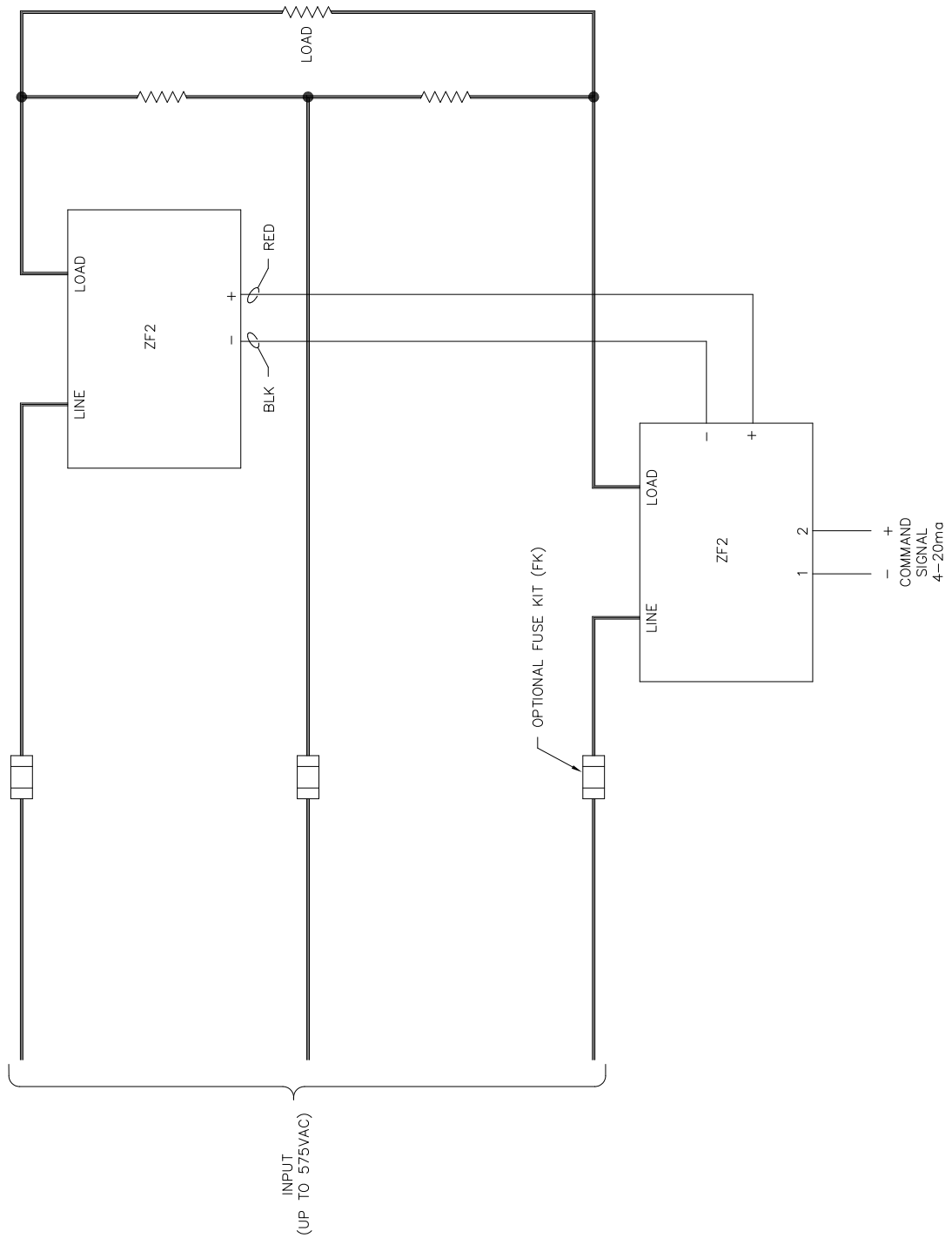

Appendix B – ZF2 System Schematic

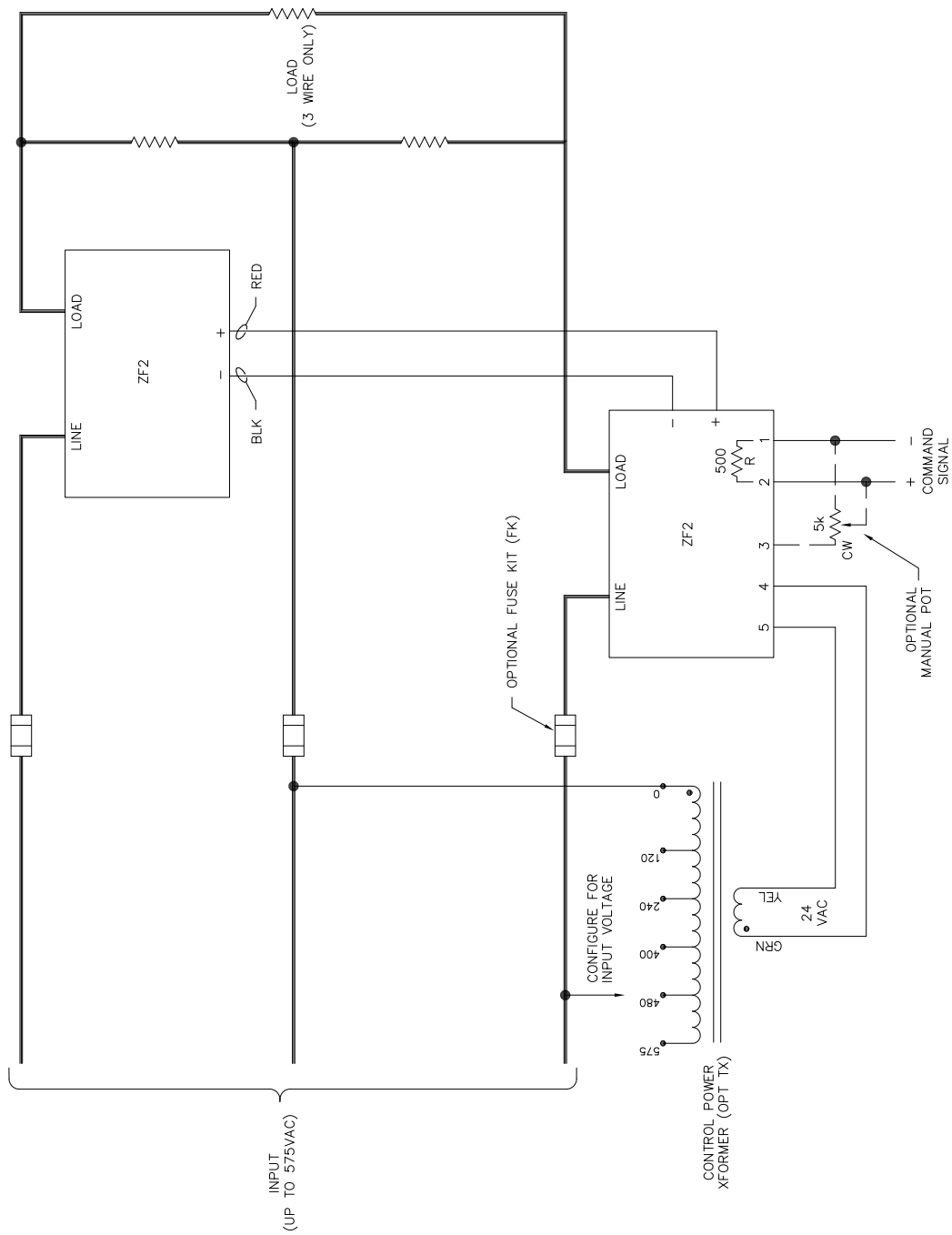

Appendix C – ZF3 System Schematic

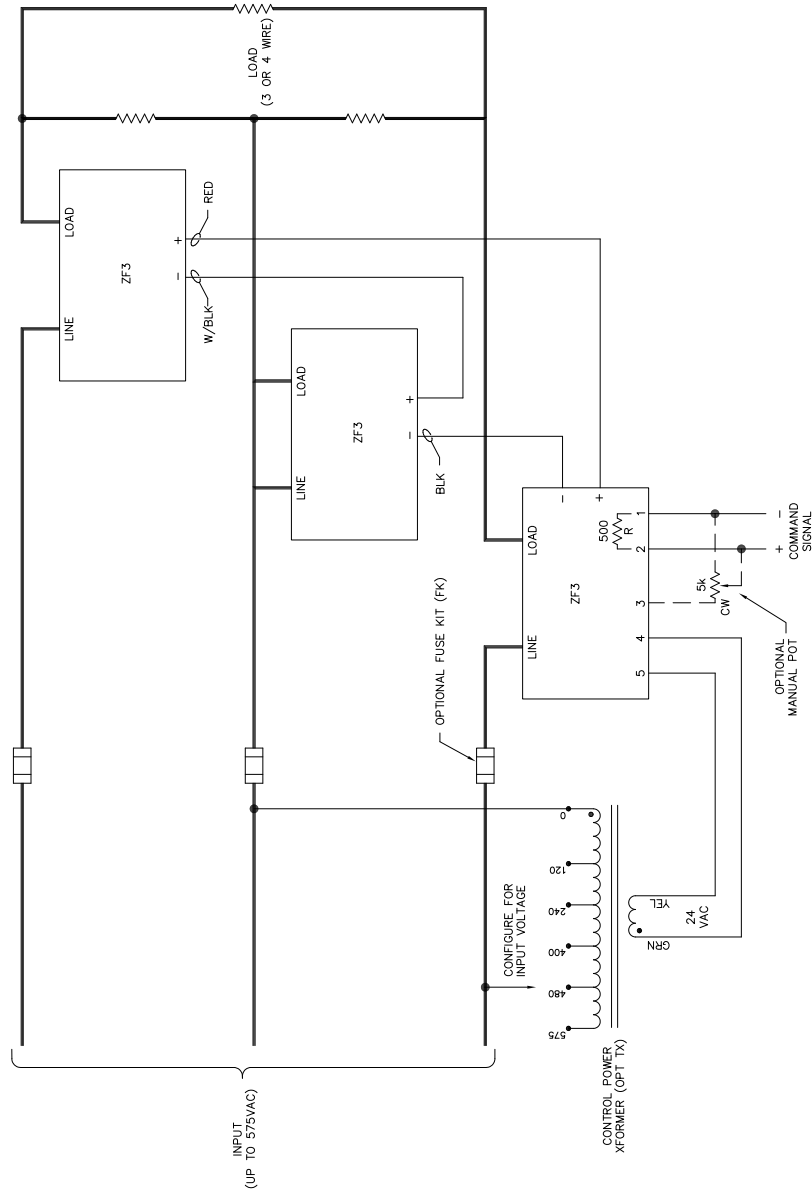

Note: Remove 500 ohm resistor with Voltage or Manual pot command signal.

Appendix D – ZF2 15-40 A Outline

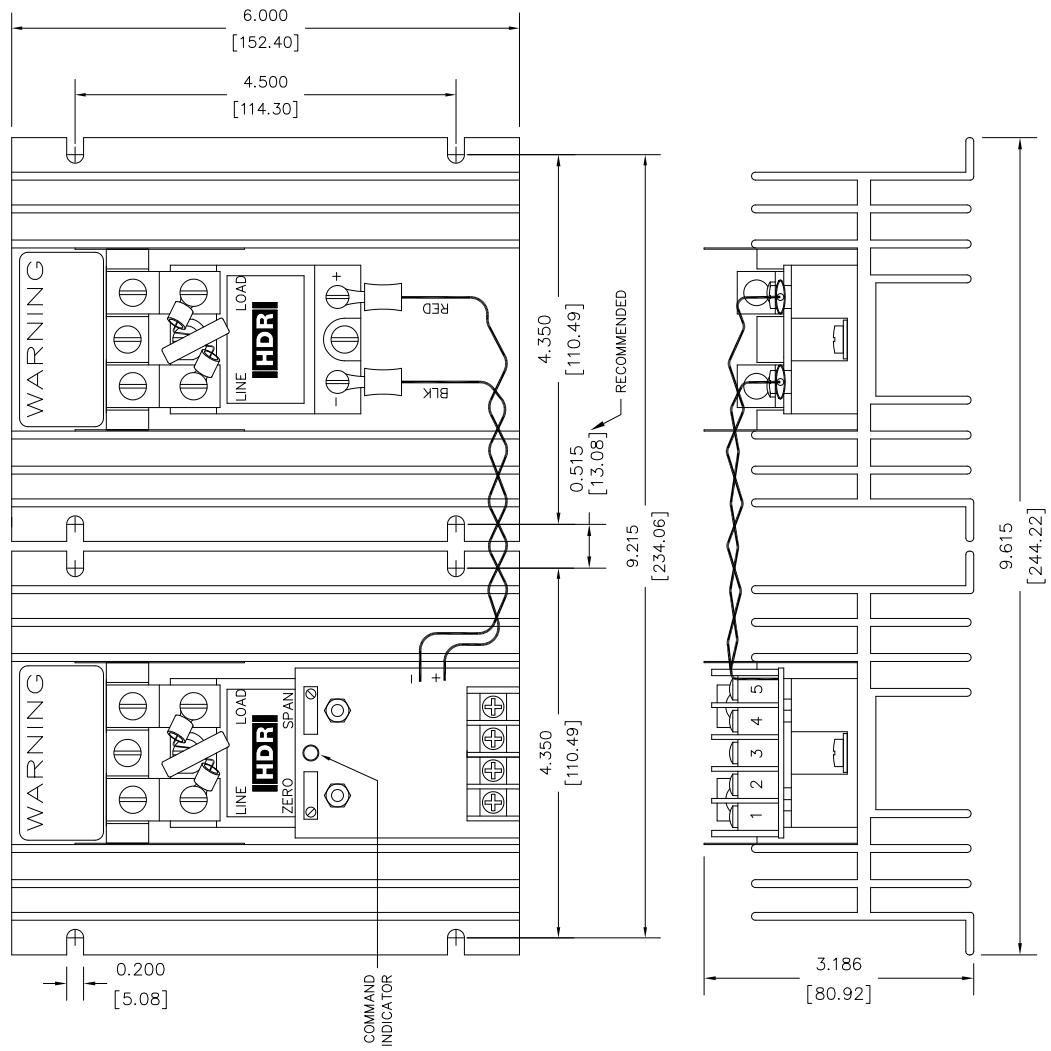

Appendix E – ZF2 70 A Outline

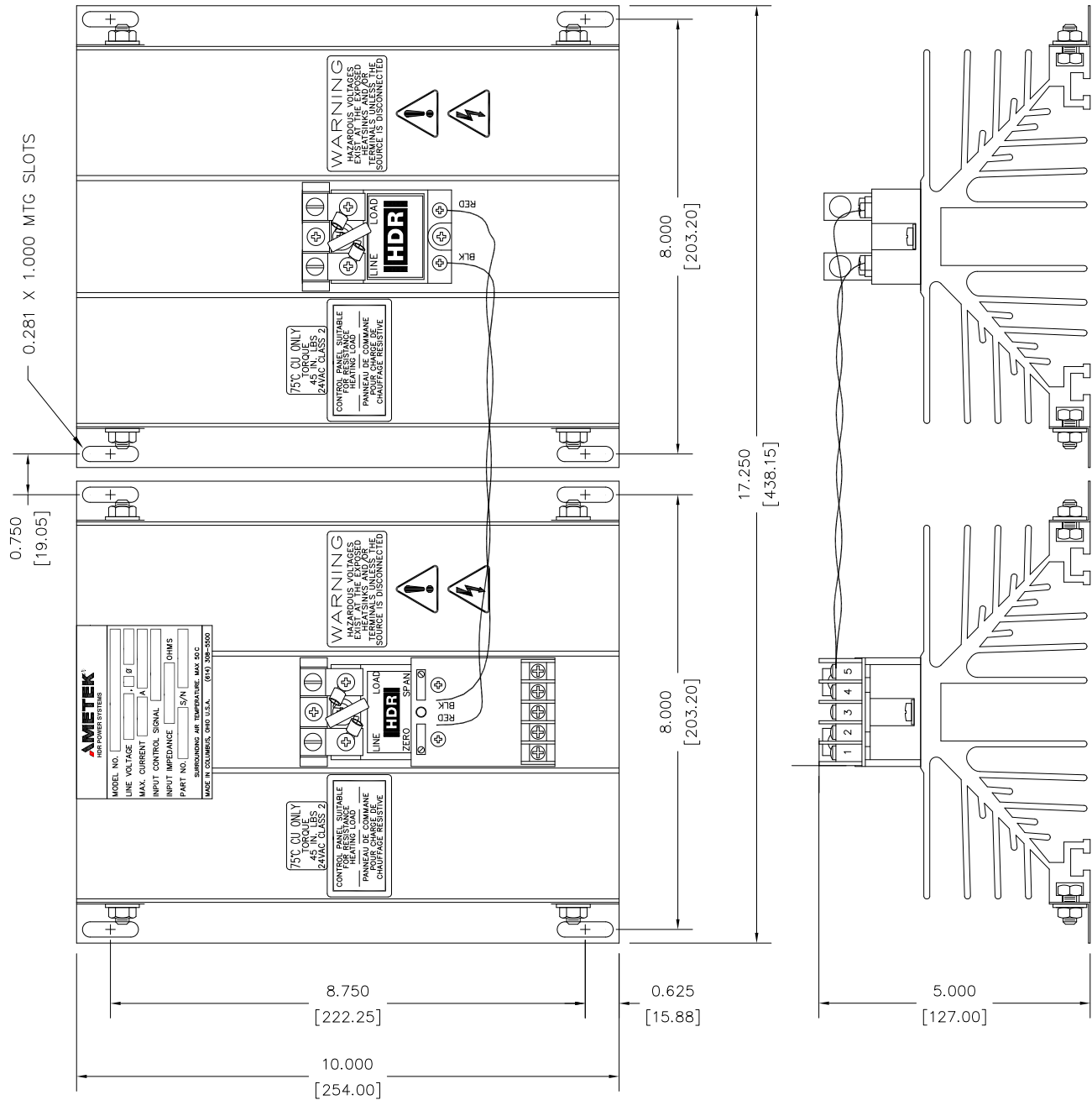

Appendix F – ZF3 15-40 A Outline

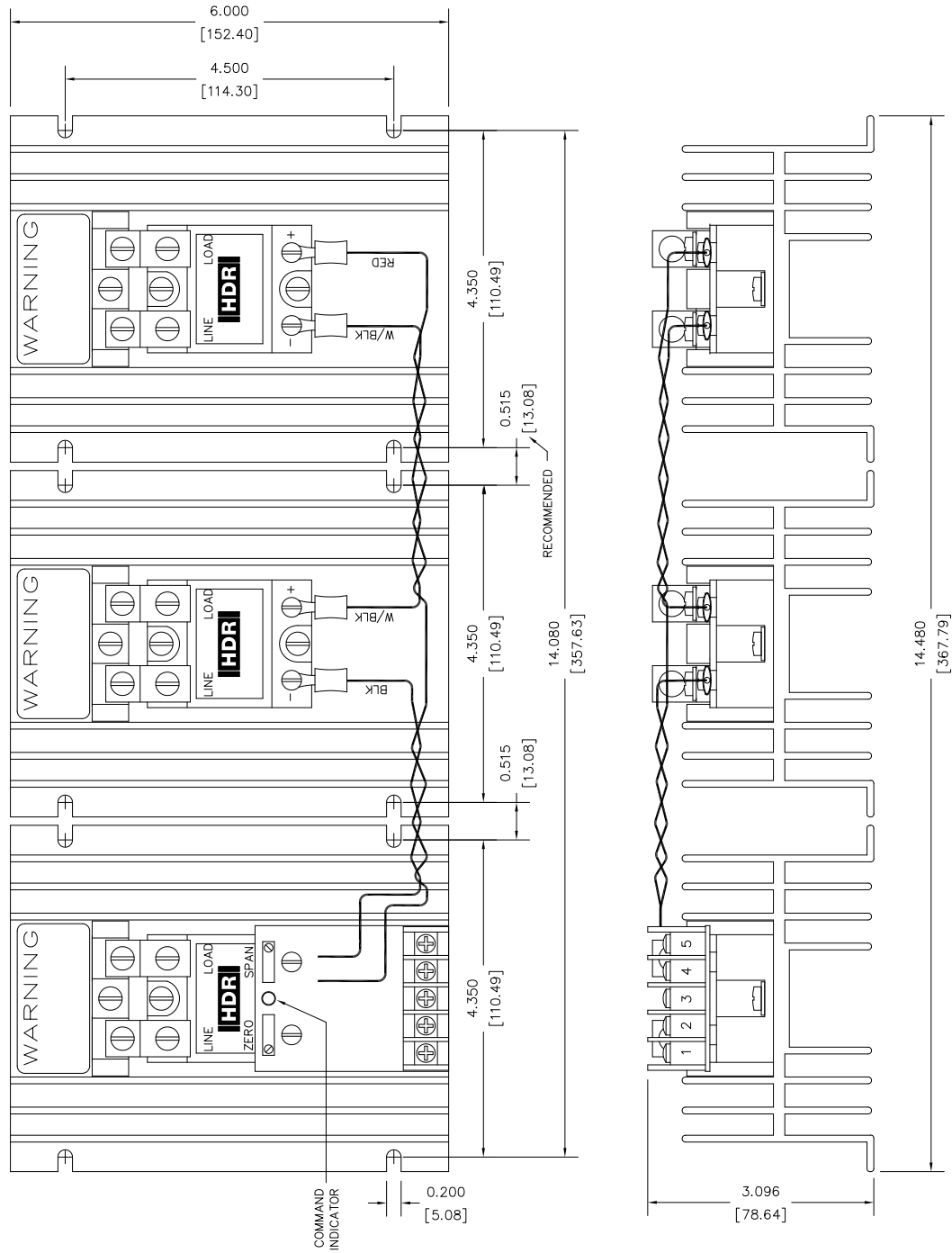

Appendix G – ZF3 70 A Outline

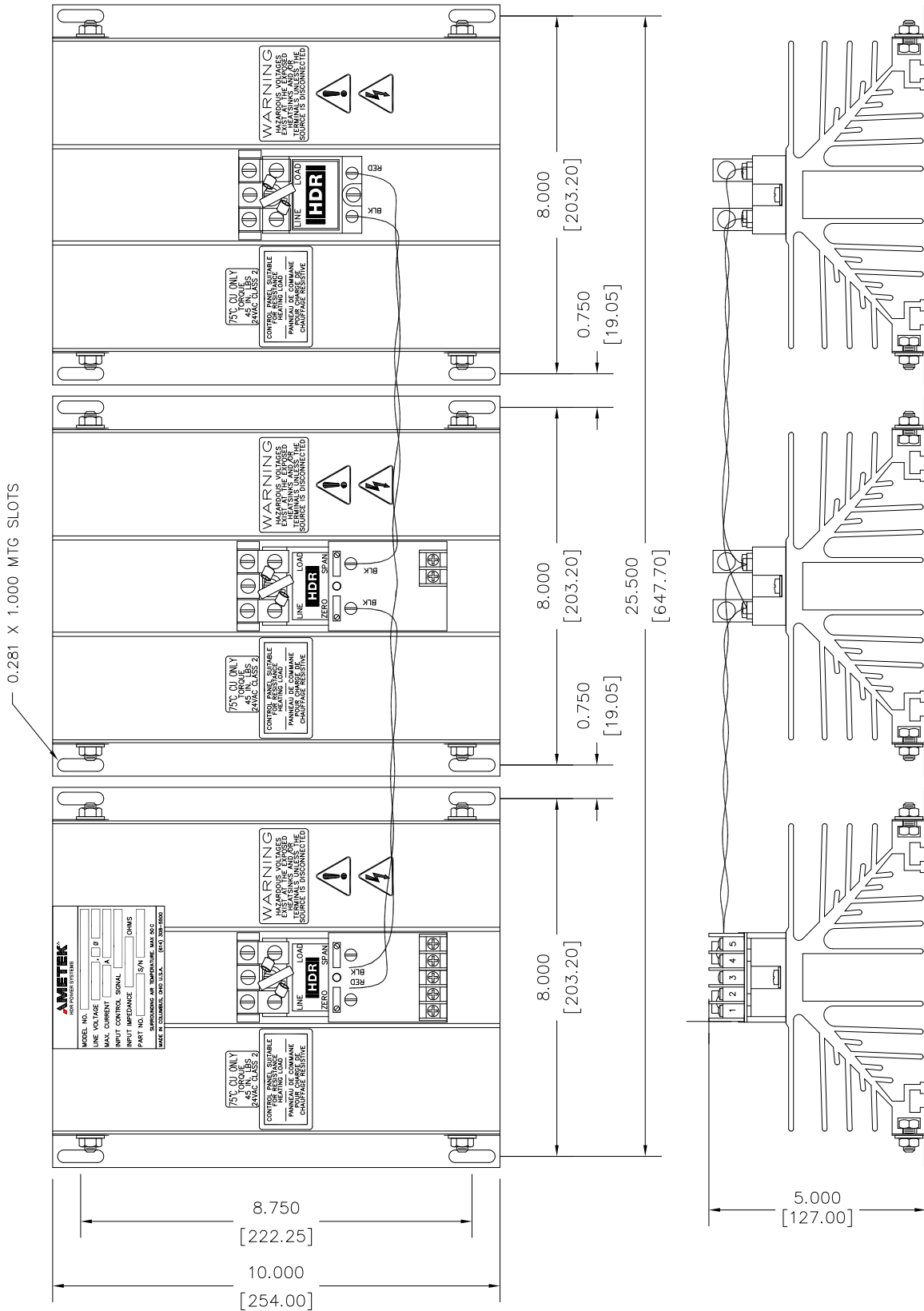

Appendix H – Option Transformer Outline

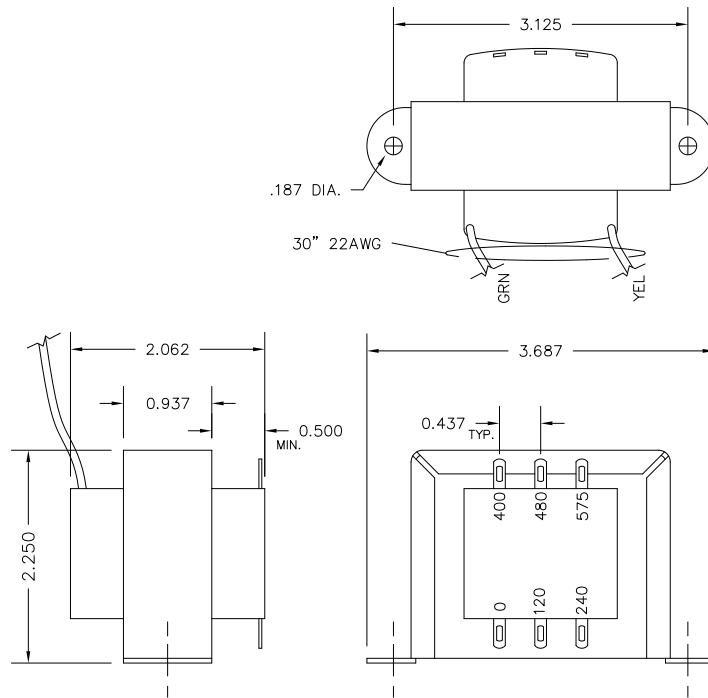

Appendix I – Option FK Mounting

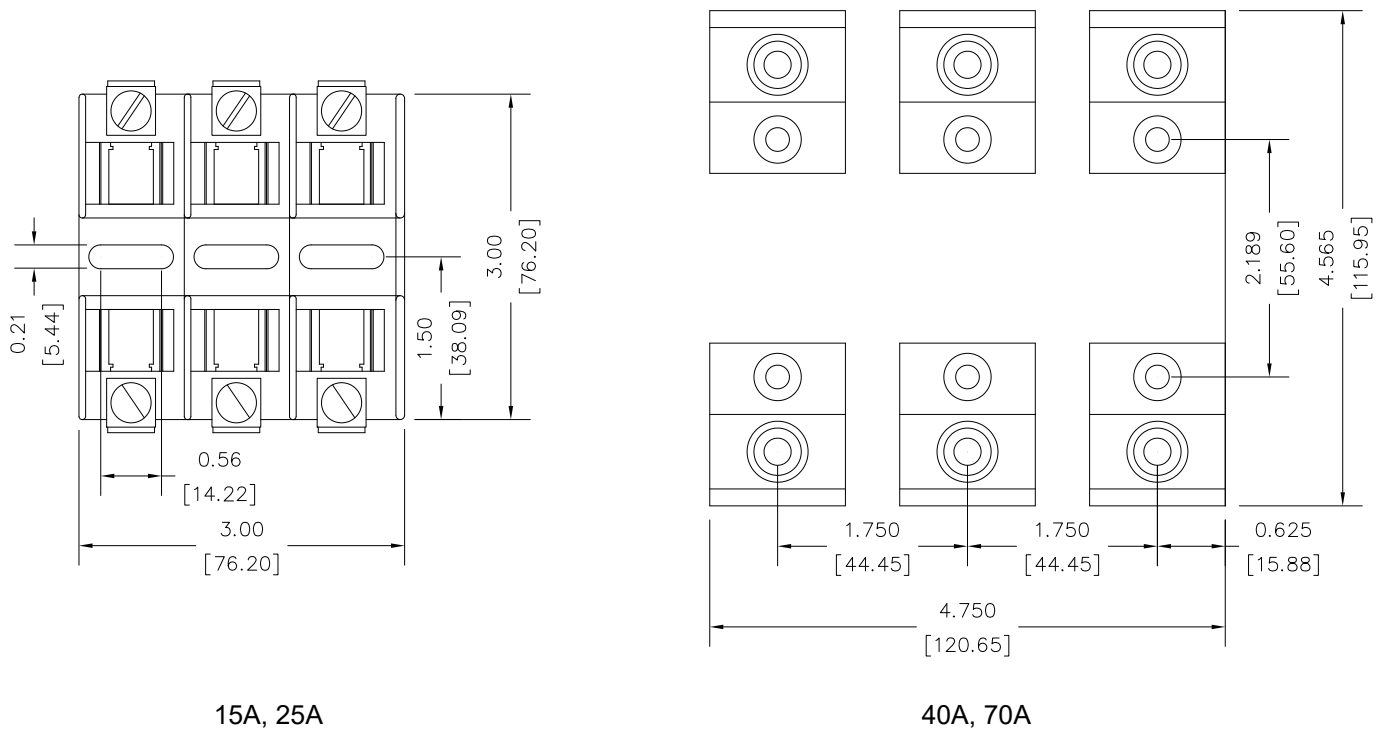

15A, 25A

40A, 70A

Appendix J – Declaration of Conformity



EC DECLARATION OF CONFORMITY

WE: **AMETEK HDR POWER SYSTEMS**
503 Lakeview Plaza Blvd, Ste C
Worthington, Ohio, 43085 - USA

Declare under our sole responsibility that the products listed below and bearing the CE label:

Type: SCR power controllers with the following model designations and current ratings:

ZF1, ZF2, ZF3, PF1, PF3 - 15, 25, 40, 60, 70, 90, 120,
180, 225, 350, 500, 650, 800, 1000 and 1200A.
SHZF1, SHPF1 - 15, 30, 40, 60, 70, 90 and 120A
SHZF2, SHZF3, SHPF3 - 15, 25, 30, 60, 90, 120, 180 and 225A
SCZF1, SCPF1 - 15, 25, 40 and 65A
All applicable options

To which this declaration relates is in conformity with the technical requirements of the following documents:

Title: Low-voltage switchgear and control gear	No. IEC 947-5-1 Year: 1990-03
Low Voltage Directive	No. IEC 73/23/EEC Year: 1973-02
Degrees of protection provided by enclosures (IP Code):	No. IEC 529-2nd Edition Year: 1989-11
Electromagnetic Compatibility	No. IEC89/336/EEC Year: 1989-05

Warning
All phase-fired (PF) controllers will require line filters and possibly shielded cables to meet the EMC requirements.

(Environmental protection classification IP00 - for mounting inside an enclosure)

Note: Characteristics are according to mfg specifications.

Name: Steve Wetta

Title: Director of Engineering

Date: July 21, 2015

Signature:

Declaration written in accordance with I.S.O. - IEC/22 Guide

Note: Certification performed on November 9, 2000 and revision is address change only

Notes:



503 Lakeview Plaza Blvd, Ste C
Worthington, Ohio, 43085 USA