

**60-1200 Amperes
Single-phase
Zero-fired**

SCR POWER CONTROLLER

Instruction, Operation and Maintenance Manual

Number: 9100037
Revision 3

AMETEK[®]
HDR POWER SYSTEMS

**530 Lakeview Plaza Blvd, Ste C
Worthington, Ohio, USA 43085**
Toll Free: 1-888-PWR-CNTL (797-2685)
Phone: 614-308-5500
Fax: 614-308-5506
Web: www.hdrpower.com

This manual applies to all Model ZF1 SCR Power Controls. Former ZF1 manual – 9100029 has been replaced with this manual.

For the support representative nearest you, please call Ametek HDR Power Systems main office at (614)-308-5500.

Revision 1	September 2014	Initial Release
Revision 2	July 2015	Revised Address
Revision 3	Aug 2022	General Revision

TABLE OF CONTENTS

IMPORTANT SAFETY INSTRUCTIONS	1
CHAPTER 1 - DESCRIPTION.....	3
1.1 General Description	3
1.2 Application	3
1.3 Operation	3
1.4 Specification	3
CHAPTER 2 - OPTIONS	5
2.1 Option LG (Lug Kit)	5
2.2 Additional Options	5
CHAPTER 3 - INSTALLATION	7
3.1 Mounting the ZF1	7
3.2 Input/Output Wiring	7
3.3 Fan Wiring (applicable to models rated 90 A and higher)	7
3.4 Wiring Overtemperature Contacts	8
3.5 Command Signal Input	8
3.6 Voltage Changeover	9
CHAPTER 4 - OPERATION	11
4.1 General	11
4.2 Front Panel Indicators	11
4.3 Command Input Control	11
4.4 Remote Manual Control with a Potentiometer	12
4.5 Auto/Manual Control with a Controller and Remote Potentiometer	13
4.6 On/Off Control	14
4.7 Shutdown	14
CHAPTER 5 - THEORY.....	15
5.1 Functional Description	15
5.2 Digital Firing Control Circuit	15
5.3 Variable-Time Base	15
5.4 Pulse-Train Firing	16
5.5 Phase-Lock Loop	16
5.6 SPAN and ZERO Controls	16
5.7 Voltage-Squared Feedback	16
5.8 Shut-down	16
CHAPTER 6 – TROUBLESHOOTING	17
6.1 Customer-Service Program	17
6.2 Troubleshooting Typical Symptoms	17
6.3 Static Precautions when Servicing	17
6.4 Environmental Problems	18
6.5 Input Power and Load Connections	18
6.6 Correcting Troubles in the ZF1 Itself	19
CHAPTER 7 - SERVICE.....	21
7.1 Communication Procedures	21
7.2 Spare Parts Orders – Routine or Emergency	21
7.3 Spare Parts List	22
7.4 Drawing List	23

CHAPTER 8 – WARRANTY POLICY	25
8.1 Warranty	25
8.2 In-house Repair Services	25
APPENDIX	27
Appendix A – ZF1 System Schematic	27
Appendix B – ZF1 60-225 A Outline	28
Appendix C – ZF1 350-500 A Outline	29
Appendix D – ZF1 650 A Outline	30
Appendix E – ZF1 800-1200 A Outline	31
Appendix F – Declaration of Conformity	32

TABLE OF CONTENTS

Par.	Title	Page
ILLUSTRATIONS		
Figure 3.1	Fan and Thermostat Connections	8
Figure 3.2	Isolated/Non-Isolated Switches	9
Figure 3.3	T1 Transformer Connections	9
Figure 3.4	Typical ZF1 Line and Load Connections	10
Figure 4.1	Control Panel	11
Figure 4.2	Process Controller Input Connections	12
Figure 4.3	Remote Control with a Potentiometer	13
Figure 4.4	Auto/Man Control with Controller and Remote Potentiometer	13
Figure 4.5	On/Off Control	14
Figure 4.6	Shutdown Control	14
Figure 5.1	AC Switch	15
TABLES		
Table 1.1	ZF1 Model Number Breakdown	3
Table 1.2	General Specifications of ZF1 Models	4
Table 3.1	Wire Size Information	7
Table 3.2	Transformer Voltage Wiring	10
Table 5.1	Variable-Time-Base Relationship (Example)	15
Table 6.1	Troubleshooting Chart (Symptoms and Solutions)	19
Table 6.2	Torque Specifications	19
Table 7.1	ZF1 Spare Parts List	22
Table 7.2	ZF3 Drawing List	23

IMPORTANT SAFETY INSTRUCTIONS



WARNING

Observe all warnings and cautions in this manual. Failure to do so may result in serious injury or death.

Refer all service to properly trained and qualified service personnel. Never work alone.

Lethal voltages exist on exposed heat sinks even if the power controller is turned off. Remove power and lock out power before attempting any service.

SAVE THESE INSTRUCTIONS

This manual contains important safety instructions that must be followed during the installation and maintenance of the SCR Power controller. Read this manual thoroughly before attempting to operate this Power controller.

An appropriate branch circuit fused disconnect or circuit breaker with this Power Controller is required to ensure the safety of operating personnel.



CAUTION

HAZARDOUS VOLTAGES exist at the Power Controller Heat Sinks and at the Load, **AT ALL TIMES**, when input voltage is connected. This condition exists even when the Power Controller is set to deliver zero output.

Printed circuit boards contain sensitive components that can be damaged by electrostatic discharge (ESD). Observe precautions for handling electrostatic sensitive devices. Reference Maintenance and Troubleshooting (Chapter 6) of this manual for details

In case of fire, use a dry chemical fire extinguisher to put out the fire. Using a liquid fire extinguisher may cause electric shock.

The SCR Power Controller makes use of components dangerous for the environment (electronic printed circuit boards, electronic components). The components removed must be taken to specialized collection and disposal centers.



CHAPTER 1 - Description

1.1 General Description

The ZF1 is Single-phase SCR Power Controller. Each of these can operate with a wide variety of input signals and line voltages up to 575 Vac and currents ranging from 60 through 1200 amperes. The ZF1's output voltage is proportional to its input signal. HDR's zero-fired SCR Power Controls utilize a variable-time-base that helps maintain constant power to the load. This variable-time-base also helps minimize temperature overshoot, temperature fluctuations and helps extend the load element's life due to reduced thermal shock. The ZF1 also features pulse-train firing which provides high immunity to possible SCR firing disturbances, and phase-lock loop circuitry which ensures line frequency synchronization. Other features are input isolation from ground, soft-start, and automatic restart circuitry. Terminals are provided to permit connection of a variety of external control methods.

1.2 Application

Zero-Fired SCR Power Controls provide control of single-phase power by the switching action of two SCRs connected back to back. By switching at the zero crossing point, RFI (Radio Frequency Interference) is virtually eliminated. Zero-Fired controllers are versatile enough to be used in place of mechanical contactors and mercury relays on dryers, kilns, ovens, environmental chambers, extruders, and most other applications where resistive heating elements are used. Normal Zero-Fired SCR Power Controllers should never be used on inductive loads.

1.3 Operation

The ZF1 accomplishes power control by the switching action of a pair of inverse-parallel power SCRs. The switching, or gating, of the SCRs is controlled by a digital firing control circuit synchronized "in phase" with line frequency (either 50 or 60 Hz). The output may be adjusted by the on-board multi-turn potentiometers or by a voltage or current signal from a process controller. ZERO and SPAN controls allow the user to calibrate the SCR unit's output to the process command signal. Terminals are available for connection of a remote manual potentiometer.

1.4 Specification

Specifications for the ZF1 SCR power controller are given in Tables 1.1 and 1.2.

Table 1.1 ZF1 Model Number Breakdown

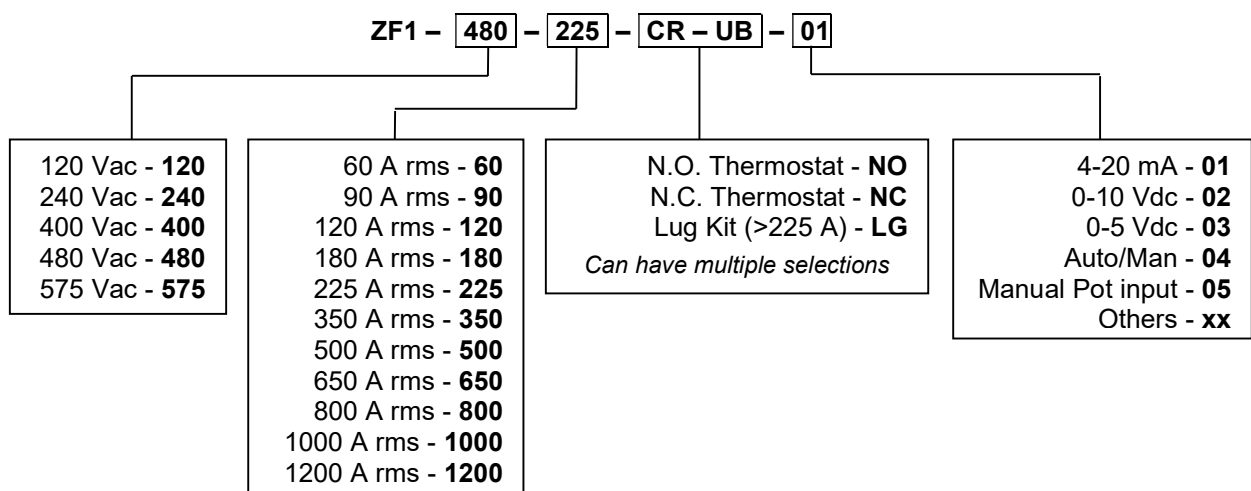

NOTE: N.O. Thermostat is included in current ratings above 60 A.

Table 1.2 General Specifications of ZF1 Models

Input line voltage: *	120, 240, 400, 480, or 575 Vac, +10%, -15% , Single-phase		
Line frequency: *	50 or 60 Hz		
Current rating: *	As indicated by model number (refer to Table 1.1)		
Thermostat contact rating:	120 Vac, 5 A; resistive		
Input Signal:			
Non-isolated	0 to 1.5 V (min); 0 to 10 V (max)		
Isolated	0 to 6 mA (min); 0 to 20 mA (max)		
Control methods:	1. Potentiometer, 5 k Ω , 1/2 watt (Customer-supplied). 2. Dry contact closure (customer-supplied). 3. Temperature or process controller**		
Control signal input impedance:			
Non-isolated input	1500 Ω		
Isolated input	500 Ω		
Control signal isolation:			
From SCRs	2,500 Vac		
From ac power input lines	2,500 Vac		
From chassis	500 Vac		
Power output:			
Power output linearity versus control signals input	$\pm 3\%$		
Power SCRs protection:			
Current surge	Subcycle I ² T semiconductor fuse.		
Transient voltage spikes (dv/dt)	Metal Oxide Varistor (MOV) and R-C snubber across each SCR pair; all SCRs have PIV rating of 1,400 V.		
SCCR Rating	100kA		
Miscellaneous:			
Zero-firing timebase	Variable see 5.3		
Controls:	ZERO and SPAN potentiometers; 10-turn, screwdriver-adjustable.		
Approvals	UL/cUL (E151547), CE		
Fan-cooling power (as applicable):			
For 90 A through 500 A units	0.21 amperes, 25 VA (50 Hz) 0.19 amperes, 23 VA (60 Hz)		
For 650 A through 1200 A units	1.2 amperes, 144 VA (50 Hz) 1.4 amperes, 168 VA (60 Hz)		
Ambient Temperature range:			
Environment	32 °F to 122 °F (0 °C to 50 °C) surrounding air Pollution degree 2 Overvoltage Category III		
Storage	14 °F to 158 ° F (-10 °C to 70 °C)		
Weight per unit	Current Rating	lbs	kg
	60 through 225 A	22	10
	350, 500 A	24	10.9
	650 A	27	12.3
	800, 1000, 1200 A	71	32.2
Outline and mounting:	See appropriate drawing in Appendix		

* Specify with order

** If you will be using temperature/process controller, specify its output; e.g., 4-20 mA, 0-10 Vdc, 2-10 Vdc, etc. with your order.

NOTE: The ZF1 should be tested or operated with an adequate load since an open output will have line voltage at the load connections.

CHAPTER 2 - Options

2.1 Option LG (Lug Kit)

Option LG will provide compression lugs for the 350-1200 A Power Controllers.

2.2 Additional Options

The options described above are the ones most commonly used. Additional options are available. For more information, contact Ametek HDR Power Systems.

CHAPTER 3 - Installation

3.1 Mounting the ZF1

Determine the voltage and current ratings from the nameplate of the unit (refer to Table 1.1). Then determine space and mounting hole requirements by referring to the outline drawing (at the Appendix) that applies to your model's current rating. Mount the unit so the line and load connections are at the top and ensure that upward airflow over the heat sink fins is unrestricted. On high current models, allow adequate clearance for routing the relatively large diameter input and output lines.

3.2 Input/Output Wiring

Using appropriately sized and insulated conductors for the voltage and current ratings of your model, make connections as shown in Figure 3.4 (Refer to Table 3.1 for wire size information). Torque specifications of bolted connections can be found in Table 6.2.

A ground wire is required for proper operation. Use a 10 AWG or larger wire.

NOTICE

Use copper conductors rated 75 °C minimum for all model current ratings.

The fuses included are NOT meant for over current protection, separate branch circuit protection is required.



WARNING

Branch circuit overcurrent protection required is to be provided in accordance with the national and local codes of the inspecting authority.

On the "internal" side of the ZF1, the wire from L2 should connect to the appropriate tap of transformer T1, depending on the line voltage to be used. Check the T1 connection by opening the ZF1 cover; T1 terminal voltages are clearly marked. Reference Chapter 3.6.

Table 3.1 Wire Size Information

Model	Size Wire/Cable
60 A	8 to 0 AWG
90 A	8 to 0 AWG
120 A	8 to 0 AWG
180 A	6 to 250 MCM
225 A	6 to 250 MCM

3.3 Fan Wiring (applicable to models rated 90 A and higher)

ZF1 models rated 90 A and higher with cooling fans require 120 Vac power which must be supplied by the customer. Fan power should be connected to terminals 21 and 22 as shown in Figure 3.1. Refer to Table 1.2 for fan power requirements by model.

The ZF1 terminals available for the 120 Vac fan connections are shown Figure 3.1 and in the schematic in Appendix A. Optional 220 Vac fans are available.

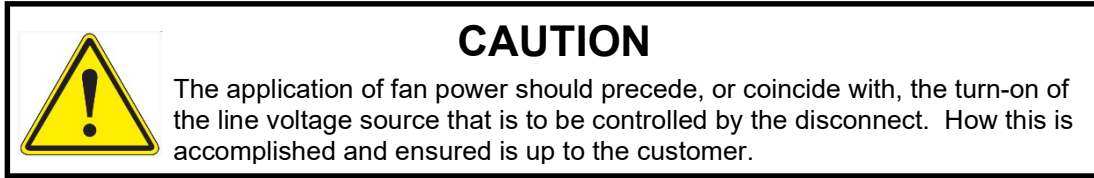

3.4 Wiring Overtemperature Contacts

Normally-open (N.O.) heat sink thermostats are standard on all fan-cooled models (rated 90 A and higher). These thermostats, which close on high heat sink temperature (200 °F), may be used to initiate an alarm, shunt trip, or other device for SCR protection. Thermostat connections are on terminals 23 and 24 as shown in Figure 3.1.

If desired, normally-closed (N.C.) contacts may be substituted for the normally-open (standard). Heat sink thermostats are optional on units with current ratings lower than 90 amperes and can be ordered with either N.O. or N.C. contacts.

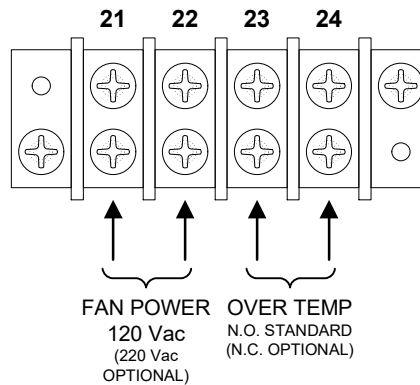

Figure 3.1 Fan and Thermostat Connections

3.5 Command Signal Input

HDR's Zero-Fired SCR Power Controllers have the capability of having either an isolated current or non-isolated voltage Command Signal input. The standard input impedance is 500 ohms for isolated and 1500 ohms for non-isolated.

All units are equipped with DIP switches, select "isolated" position for a 4-20 mA command signal and "non-isolated" for a voltage input such as 0-10 Vdc. See Figure 3.2.

The isolated input works best with an offset Command Signal such as 4-20 mA; however, it will work with both offset and zero based Command Signals. Zero based Command Signals may have a small amount of non-linearity (input to output) at the low end. This should not be a problem on closed loop systems.

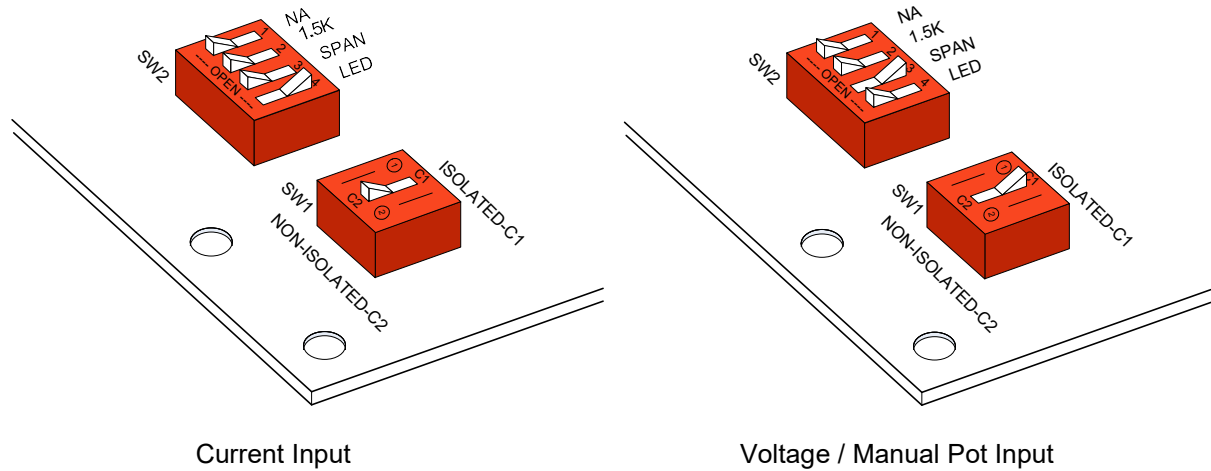



Figure 3.2 Isolated/Non-Isolated Switches

3.6 Voltage Changeover

On occasion, customers may wish to operate a ZF1 SCR Power Controller on line voltages other than what was specified when originally ordered. The ZF1 may be changed to accept a wide range of line voltages (120, 240, 400, 480, 575 Vac), so long as the load current does not exceed the ZF1’s current rating. This is accomplished by performing the procedure described below.



WARNING

Voltage changeover should be performed by qualified personnel only. Always remove power and properly lock out power to the unit before attempting any service.

Using the system schematic (located in the Appendix) as reference, perform the voltage changeover procedure as follows.

1. Open the SCR power controller, and locate transformer T1. The primary side of T1 transformer will contain two wires (one black, the other white and black). Refer to figure 3.3.

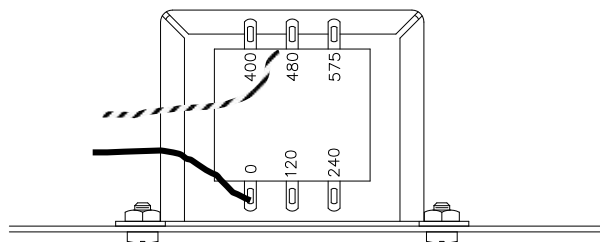

Figure 3.3 T1 Transformer Connections

2. Unsolder the Black/White wire on T1 from the voltage tap, and resolder it to the tap desired, as shown in Table 1. Route the wires so that they are physically located under the transformer terminals

Table 3.2 Transformer Voltage Wiring

Desired Voltage	T1 White & Black Wire to
120	120
208	240
220	240
240	240
380	400
400	400
415	400
480	480
575	575

- Close the unit, and apply line power. The unit is now ready for operation on the line voltage selected. It is a good idea to identify the unit with a label or tag, noting that ZF1 has been modified for line voltage other than what it was specified for. This may prevent accidental use on an incorrect line voltage in the future.

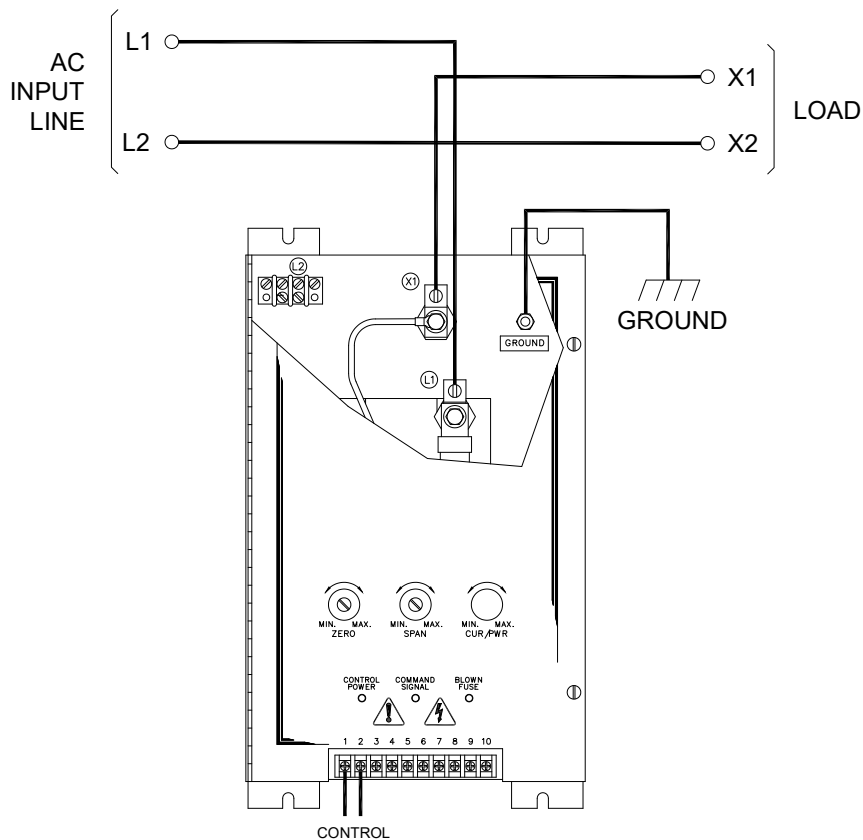

Figure 3.4 Typical ZF1 Line and Load Connections

CHAPTER 4 - Operation

4.1 General

This Chapter provides information necessary for proper setup and operation of various methods used to control the ZF1.

- a. Front Panel indications
- b. Command input control
- c. Remote manual control with a potentiometer
- d. Auto/manual control with a controller and potentiometer
- e. On/off control
- f. Shutdown

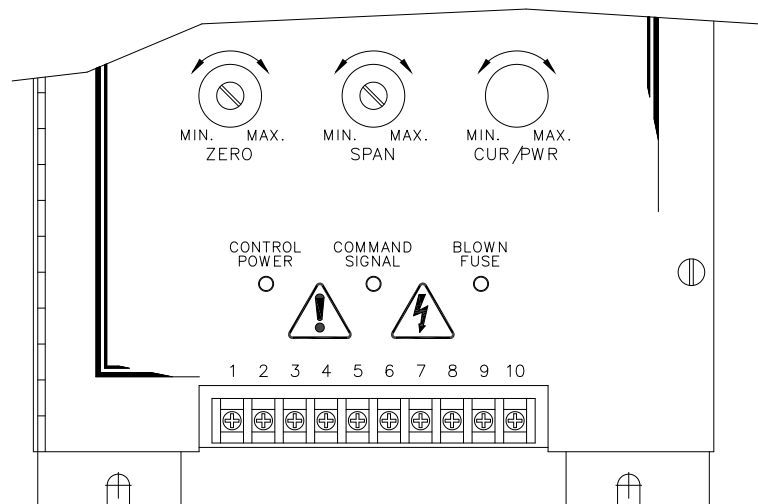

Figure 4.1 Control Panel

4.2 Front Panel Indicators

Control Power Indicator – A Red Light Emitting Diode (LED) located on the front cover of the unit signals when the control power is present.

Command Signal Indicator - The Command Signal Indicator is a green Light Emitting Diode (LED) located on the front cover of the unit. The brilliance of this LED will change with a current Command Signal. The brilliance increases with an increased Command Signal and decreases with a decreased Command Signal. The LED will not function with a voltage or manual input.

Blown Fuse Indicator - The Blown Fuse Indicator is a yellow Light Emitting Diodes (LED) located on the front cover of the unit. Switch on the fuse controls the LED.

4.3 Command Input Control

The ZF1 is calibrated at the Factory for the specified input type and normally does **NOT** need adjustment. However, should a setup be required use the following methods. Refer to chapter 3.5 for the Command signal input configuration.



WARNING - ELECTRIC SHOCK CAN KILL
HAZARDOUS VOLTAGES exist at the output terminals and at the load when the input voltage is connected. This condition exists even when the Controller is set to deliver zero output. Always remove power and properly lock out power to the unit before attempting any service, including the load.

- a. Set the **ZERO** and **SPAN** controls fully CCW (counterclockwise).
- b. Connect a voltmeter across terminals X1 and X2 of the ZF1. Set the voltmeter range to measure full input voltage.
- c. Close the fused disconnect or circuit breaker to apply power to the ZF1. Turn the Process controller on and set to demand zero power output.

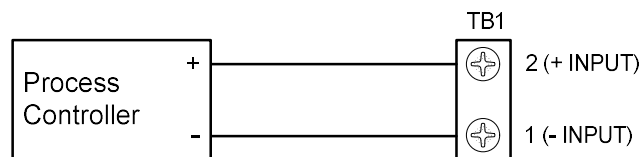

Figure 4.2 Process Controller Input Connections

- d. Adjust the **ZERO** control CW until the output just turns on, then turn the **ZERO** control CCW just to the point where the output voltage reading is zero.
- e. Set the Process controller to demand 100% output. Observing the voltmeter, adjust **SPAN** CW just to the point where the reading is below the maximum output voltage. Then adjust **SPAN** CW just to the point where the meter reading is at maximum.
 Note: The output voltage measurement on Zero Fired Power Controllers with a digital voltmeter will be erratic except at full output. This is due to the variable pulses to regulate the output.
- f. Repeat steps 4.3f and 4.3e as necessary, to ensure proper control adjustments have been made.
- g. Turn off the line power to the ZF1 and disconnect the test equipment. The ZF1 is now ready for automatic operation.

4.4 Remote Manual Control with a Potentiometer

Some applications only require a manual control input and not a closed loop input from a process controller. This potentiometer may be located on a remote panel near other controls related to the process being powered by the ZF1. It may be calibrated to correspond to a percentage of rated power output, process temperature, or some other parameter. The potentiometer may be 500 Ω to 5 k Ω , and should be rated at 1/2 watt, minimum.

- a. With the power to the ZF1 turned off, connect the potentiometer as shown in Figure 4.3. The CW position is the full power output position. Terminal TB1-5 is internally connected to a positive dc voltage source.
- b. Connect a voltmeter across terminals X1 and X2 of the ZF1. Set the voltmeter range to measure the full output voltage.
- c. Set the **SPAN** control and remote potentiometer fully CCW.
- d. Close the fused disconnect or circuit breaker to apply power to the ZF1. The unit should be energized, with no output.

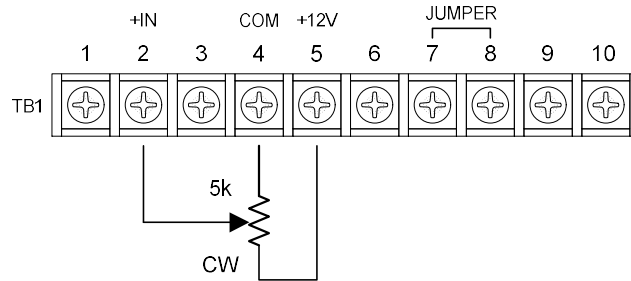

Figure 4.3 Remote Control with a Potentiometer

- e. Adjust the **ZERO** control CW until the output just turns on, then turn the **ZERO** control CCW just to the point where the output voltage reading is zero.
- f. Set the **SPAN** control and remote potentiometer fully CW. The output should be full-on.
- g. Observe the voltmeter and slowly adjust the **SPAN** control CCW, just to the point where the output voltage reading is at maximum.
- h. If necessary, readjust **ZERO** with remote potentiometer fully CCW and **SPAN** control and remote potentiometer fully CW.
- i. Turn off the line power to the ZF1 and disconnect the test equipment.

4.5 Auto/Manual Control with a Controller and Remote Potentiometer

On closed loop processes it may be desirable to be able to operate the unit manually. The SCR Power Controller has this capability designed into it. Connect the Command Signal, a Remote Manual control and an Auto/Manual switch in the Auto position. By switching to the Manual position, the Remote Manual control operates and the auto signal is disconnected.

With the power to the PF1 turned off, connect the switch, potentiometer, and controller as shown in Figure 4.4 and remove jumper from terminal TB1-7 and TB1-8. Install the **AUTO/MAN** switch in the same general location as the remote manual potentiometer. Note that the full CW position of the potentiometer is the full-power-output position.

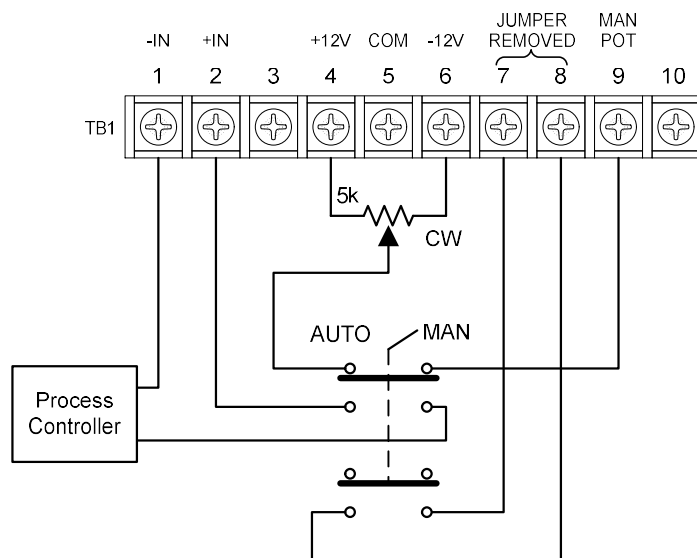

Figure 4.4 Auto/Man Control with Controller and Remote Potentiometer

Place the **AUTO/MAN** switch to **AUTO** and calibrate the system as described in steps 4.3b through 4.3h.

4.6 On/Off Control

Some applications require that a simple ON/OFF type control be used. The unit can be used in these simple applications. It can be connected for turn on by a contact closure.



WARNING
This method of control is not to be used with isolated inputs!

With the ZF1 configured for non-isolated inputs and the power to the ZF1 turned off, connect the system as shown in figure 4.5. A closed contact will turn on (enable) the ZF1.

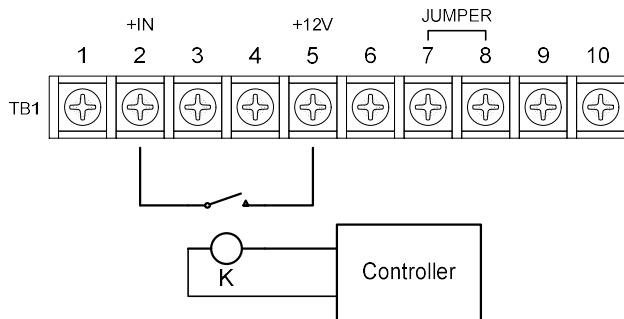
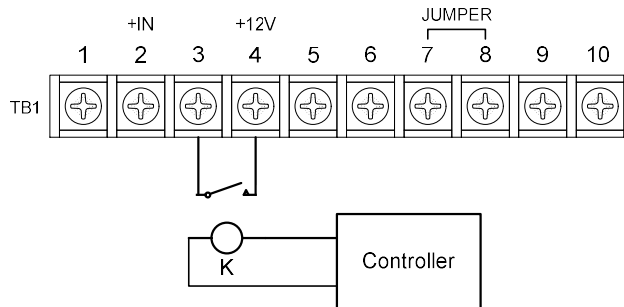

Figure 4.5 On/Off Control

Calibrate the system by performing the steps in 4.3. Note that zero power demand is accomplished by opening the contacts with the controller, and maximum power demand is present when the contacts are closed.

4.7 Shutdown

When it is necessary to shutdown or disable the output, it is a simple matter. Connect a dry contact closure between terminals 3 and 4 of the firing circuit as shown in Figure 4.6. A closed contact will disable the ZF1 output.



**Figure 4.6 Shutdown Control
(Output Disabled By Contact Closure)**

CHAPTER 5 - Theory

5.1 Functional Description

The main function of the ZF1 is to control the amount of power delivered to a load.

The SCR is either on or off and conducts in one direction when turned on. Because the SCR only conducts in one direction, two SCR's are connected in "inverse parallel" configuration, Figure 5.1. A small gate signal is applied to turn on the SCR. Once the SCR is turned on, it will remain On until the current through the SCR goes below the holding current level.

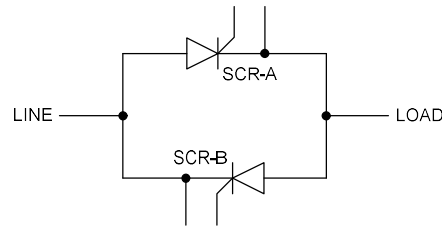

Figure 5.1 AC Switch

5.2 Digital Firing Control Circuit

Firing (gating) of the SCRs is controlled by a digital firing control circuit synchronized to the line frequency (50 or 60 Hz). The firing control circuit may be manually controlled by the built-in ZERO control or a remote potentiometer. Automatic control may be from a temperature or process controller that provides a demand-proportional low-level voltage or milliampere output signal. The firing control circuit may also be turned on and off by an external switch or relay contacts. (Chapter 4 discusses some external control methods.)

5.3 Variable-Time Base

The firing control circuit of the ZF1 operates on a variable rather than fixed time base. Operating on a fixed-time base of 1/3 second (20 cycles), for example, at 50% power the SCRs would be on for 10 cycles, off for 10 cycles, on for 10 cycles, and so on. Operating on a variable-time-base, at 50% power, the SCRs are on for one cycle and off for the next. At 75% power, the controller, with a fixed-time-base of one-third second (20 cycles), would be on for 15 cycles and off for 5. The variable-time-base, however, would be on for three cycles, off for one, and so on. The time required to describe the operation of the ZF1 would be the period of four cycles in this case – three cycles on and one cycle off.

Table 5.1 Variable-Time-Base Relationship (Example)

Control signal, % Power Demand	SCR Pair, Complete On Cycles	SCR Pair, Complete Off Cycles
1%	1	99
25%	1	3
50%	1	1
60%	3	2
70%	7	3
75%	3	1
80%	4	1
90%	9	1
95%	19	1
99%	99	1
100%	∞	0

For 50% power, the time required to describe the operation of the variable-time-base would be the period of two cycles – one cycle on and one cycle off. Hence the time-base of the ZF1 would be the period of two cycles for 50% power and four cycles for 75% power. The time-base varies for other power levels as well, so its period is always that of a whole number of cycles. This theoretical relationship is shown in Table 5.1. It may not appear precisely as indicated when the output is viewed with an oscilloscope, as other factors such as voltage feedback may be occurring.

An important consideration is that, for discrete cycles of output, the “off” time is the minimum possible for any specific power demand (see above). This reduces thermal shock to the load and thus extends load element life. Of equal importance, variable-time-base firing provides excellent control resolution and fast response, and the circuit design facilitates accurate voltage regulation. The lowest shock factor the load is achieved at 50% output (one cycle on, one cycle off).

5.4 Pulse-Train Firing

The output of the ZF1 to the SCRs consists of a pulse-train of approximately 17 kHz. This means that for every cycle of controlled output, the SCRs would receive approximately 142 trigger pulses, which will ensure constant gating during the “on” period of the ZF1’s output. This also ensures that the SCR is gated on in case of a mid-cycle turnoff.

5.5 Phase-Lock Loop

When the output of the oscillator is locked to the input signal, it is said to be “locked” in phase. The control voltage is such that the frequency of the voltage controlled oscillator is exactly equal to the frequency of the input signal. For each cycle of input there is one cycle of oscillator output. By this method, the ZF1’s output will be held at 50 Hz or 60 Hz, depending on configuration. The input signal is filtered, then compared to the oscillator, improving noise immunity over conventional sync circuits.

5.6 SPAN and ZERO Controls

The ZERO and SPAN potentiometers are screwdriver adjustable. The center position of the ZERO control corresponds to zero bias and zero power output. The approximate zero setting can be found by rotating the control over its range, stopping near the midpoint of rotation. The precise zero setting can be found by observing the output level while rotating the control near the midpoint of rotation. From the midpoint to extreme CCW (counterclockwise) is the zero or negative region. Operating the control in this region, one can zero the output from the ZF1 at any output level of a temperature controller or other external control device. From midpoint to extreme CW is the positive control region, whose extremes correspond to 0% and 100% power output, respectively, as manually adjusted.

The SPAN control is used as a final adjustment to set the ZF1 output to precisely 100%, when the principal control device (external controller, external “manual” control or ZERO potentiometer) is set to demand 100% output.

5.7 Voltage-Squared Feedback

Voltage-squared feedback simulates power feedback. It is used to help maintain constant power delivered to the load when the line voltage changes and the load resistance remains constant.

5.8 Shut-down

The shutdown circuit provides a quick SCR shutdown signal. This is accomplished via a customer provided contact across terminal 3 and terminal 4. This removes the input signal to the comparator that tells the circuit when to gate the SCRs on. It also instantaneously turns off the SCR gating pulses.

CHAPTER 6 – Troubleshooting

6.1 Customer-Service Program

Although service is seldom necessary, because of the inherent long-term reliability of solid-state components and conservative design, Ametek HDR Power Systems emphasizes customer satisfaction by maintaining a rapid-response and cooperative customer-service. If operational difficulties occur, Ametek HDR Power Systems will provide replacement parts or units quickly, courteously and efficiently. If servicing problems arise that are not within the scope of the following troubleshooting guide, service is readily available, as detailed in Chapter 6.

6.2 Troubleshooting Typical Symptoms

The ZF1 is considered to be operating properly when its output voltage can be satisfactorily varied from 0% to 97% of the available input voltage by a control signal. Improper operation of the unit is usually indicated by one of the following symptoms:

- a. No output.
- b. Full output at all times, with no change resulting from a control signal change.
- c. Output variable from some intermediate value to maximum, but cannot be brought to zero.
- d. Output variable from zero to some intermediate value, but cannot be brought to maximum.

The symptoms listed may be caused by one or more of the following: an environmental problem, faulty input-power or load connections, and the ZF1 itself. These possible causes should be investigated as described in Chapters 6.4 through 6.6.



WARNING - ELECTRIC SHOCK CAN KILL
HAZARDOUS VOLTAGES exist at the exposed heat sinks and at the load unless the line-source fused disconnect or circuit breaker is open or off. This is true even when the SCRs are turned off. Always remove power and properly lock out power to the unit before attempting any service is performed.

6.3 Static Precautions when Servicing

Servicing should be performed by qualified personnel only, following procedures described herein.



ATTENTION
Printed circuit boards contain sensitive components that can be damaged by electrostatic discharge (ESD). Observe precautions for handling electrostatic sensitive devices.

If troubleshooting indicates a need to replace a component on a printed circuit board or possibly the entire board, measures to prevent electrostatic discharge (ESD) damage must be taken.

- a. ALWAYS wear a wrist strap connected to ground through a 1-megohm resistor when working on printed circuit boards.
- b. Use soldering iron with a grounded tip.
- c. Use a non-static solder sucker (metallic) or solder removal braid.

- d. Transport static sensitive components in static shielding bags or rails. A new printed circuit board should be treated as a static sensitive device. A part completely installed on a board does not make the part static-safe.
- e. If possible, perform printed circuit board maintenance at a work station that has a conductive covering which is grounded through a 1-megohm resistor. If a conductive table top is unavailable, a clean steel or aluminum table top is an excellent substitute.
- f. Keep plastic, vinyl, Styrofoam or other non-conductive materials away from printed circuit boards. They are good static generators that do not give up their charge easily.
- g. Return goods to Ametek HDR Power Systems in static-safe packaging. This will limit further component damage from ESD.
- h. CAUTION. Do not touch any printed circuit board unless you are wearing a ground wrist strap, as circuit damage may occur. Grounding kits are also available commercially and can be purchased through most electronic wholesalers.

6.4 Environmental Problems

Check to see that none of the following environmental problems exist.

Inadequate Cooling. For 350 A and larger models, allow at least 3 inches of air space (in any direction) between the heat sinks and any item or structure near the ZF1 power modules. Heat sink fins should be free of dust or dirt for proper heat transfer, and free of obstructions which could prevent proper airflow.

Contamination. The unit should be periodically cleaned of all dust and dirt. However, certain kinds of dust or particles are particularly conductive. A small accumulation of conductive material can cause component failures from arc-over or complete shorts.

High Ambient Temperature. Lack of a proper ambient-temperature check before installation, or an increase in ambient temperature, can result in numerous problems. Check the ambient temperature under existing conditions. If it is 122 °F (50 °C) or lower, ambient temperature should not be a problem. If it is above 122 °F (50 °C), steps should be taken to provide more cooling, or the ZF1 should be moved to a cooler location, or call the Ametek HDR Power Systems service department.

Excessive Vibration. A significant degree of pitched or unpitched vibration can cause numerous problems. If vibration is isolated as a probable cause of improper operation, standard vibration-isolation mounting techniques should be employed.

6.5 Input Power and Load Connections

Turn off the power to the ZF1 and check all power connections, input and output, to make sure they are mechanically secure and free of corrosion. Make the same checks at the power source and load. Visually check insulation on input and load wiring for evidence of damage or overheating.

6.6 Correcting Troubles in the ZF1 Itself

Table 6.1 provides a comprehensive guide for troubleshooting the ZF1.

Table 6.1 Troubleshooting Chart (Symptoms and Solutions)

Cause	Solution
No output even with manual control (Zero) turned full CW.	
(1a) Open SCR fuse	Disconnect power and check the fuse. If it has opened, replace it <u>after</u> completing (b)
(1b) SCRs not firing	Install a good fuse in the circuit, and apply power to the ZF2/ZF3. If the output is fully controllable using the manual control, then resume normal operation. If the power output is still zero, contact Ametek HDR Power Systems service.
Maximum power at all times regardless of control setting.	
(2a) All SCR networks shorted	On units rated above 225 A; Disconnect power and check the front-to-back SCR pairs by measuring resistance between the cathode of the SCR being checked and an unanodized portion of the heat sink. On the Rx1 scale, the resistance should be infinite in both directions. If a shorted component is indicated in any of these checks, replace it. On units rated at 225 A and below: Disconnect power and check the front-to-back SCR pairs by measuring resistance between terminals L1 (of the SCR) and X1. On the Rx1 scale, the resistance should be infinite in both directions. If a shorted component is indicated in any of these cases, replace it.
(2b) Firing control section defective	Return the power to the unit. If the problem persists, contact Ametek HDR Power Systems service.
Output is variable but can't be brought to zero with ZERO control	
(3a) SCR network shorted	Check SCR network per solution 2a.
(3b) Firing control section defective	Contact Ametek HDR Power Systems service for assistance
Output is variable but can't be brought to maximum with SPAN control	
(4a) Firing control section defective	Contact service for assistance

Table 6.2 Torque Specifications

INPUT/OUTPUT CONDUCTOR SIZE, AWG OR CIR. MILS	TORQUE, INCH POUNDS		
	SLOT WIDTH*		HEX HEAD (ALL)
	1/4" OR LESS	OVER 1/4"	
6-4 AWG	25	45	110
2 AWG	35	50	150
1 AWG	40	50	150
1/0 – 2/0 AWG		50	180
3/0 – 4/0 AWG		--	250
250 – 350 MCM		--	325
500 – 700 MCM		--	375
800 – 1000 MCM		--	500

* = Screwdriver Blade Width to Match

(With Socket-Head Screws, all Conductor Sizes)

SOCKET SIZE, ACROSS FLATS	TORQUE INCH POUNDS
3/16"	120
1/4"	200
5/16"	275
3/8"	375
1/2"	500

CHAPTER 7 - Service

7.1 Communication Procedures

If operational problems arise that cannot be resolved by review of all related procedures given in this manual, please contact "Service" at Ametek HDR Power Systems. Please have your model number and serial number of the unit ready as it is required for our technicians to assist you.

NORMAL BUSINESS HOURS 8 am to 5 pm, USA EASTERN TIME ZONE, Monday through Friday.

TELEPHONE 614-308-5500. Our Answering Service will accept your message during all off-hours, including weekends. We receive those messages at 8 am on the next normal workday. We will respond at the earliest time possible, within your time zone and normal work day.

FACSIMILE 614-308-5506. Automatic reception during all hours.

If you are experiencing downtime or other critical circumstances during our off-hours (see above), and wish to telephone us, please inform our Answering Service operator of the nature and degree of your problem. In such cases the operator is authorized to call Ametek HDR Power Systems Service. We cannot, however, guarantee that service assistance will be available at any given off-hour time.

When we are reached by phone, our first step will be to give you over-the-phone assistance at no charge. If the problem cannot be resolved by phone we will arrange for service at your site or by shipment to Ametek HDR Power System, as you request. We will make every possible attempt to support your emergency, on-site needs, regardless of how contacted.

7.2 Spare Parts Orders – Routine or Emergency

Requests for spare parts should be directed to "Inside Sales" at Ametek HDR Power Systems during normal hours, if possible, or via any method shown above for off-hours. Often we can provide same-day delivery for critical circumstances. When contacting us, please present as much information as possible – the related equipment Model Number and Serial Number; the required part name and any identifying part of vendor number(s); and your time needs. An approved Purchase Order Number should be given with your order.

7.3 Spare Parts List

The following table lists the minimum recommended quantities for spare parts for the ZF1. As spares are used, replacements should be ordered.

The listed SCR current ratings are the half-wave average values. The calculation for half-wave average value is nameplate current times 0.45.

Table 7.1 ZF1 Spare Parts List

Item	Item No.	Qty
60 Ampere Units		
Fuse, 80 A, 700 V	7580070I	1
PCB Assy, ZF1	2099161	1
PCB Assy, DVDT	2099000	1
SCR/dual pkg, 90 A, 1400 V	6791114	1
90 Ampere Units		
Fan, Axial, 115 Vac, 110 CFM	4520001	1
Fuse, 125 A, 700 V	7512170I	1
PCB Assy, ZF1	2099161	1
PCB Assy, DVDT	2099000	1
SCR/dual pkg, 90 A, 1400 V	6791114	1
120 Ampere Units		
Fan, Axial, 115 Vac, 110 CFM	4520001	1
Fuse, 150 A, 700 V	7515170I	1
PCB Assy, ZF1	2099161	1
PCB Assy, DVDT	2099000	1
SCR/dual pkg, 90 A, 1400 V	6791114	1
180 Ampere Units		
Fan, Axial, 115 Vac, 110 CFM	4520001	1
Fuse, 225 A, 700 V	7523170I	1
PCB Assy, ZF1	2099161	1
PCB Assy, DVDT	2099000	1
SCR/dual pkg, 142 A, 1400 V	6712114	1
225 Ampere Units		
Fan, Axial, 115 Vac, 110 CFM	4520001	1
Fuse, 300 A, 700 V	7530170I	1
PCB Assy, ZF1	2099161	1
PCB Assy, SCR, DVDT	2099000	1
SCR/dual pkg, 162 A, 1400 V	6722114	1
350 Ampere Units		
Fan, Axial, 115 Vac, 110 CFM	4520001	1
Fuse, 450 A, 700 V	7500123	1
Lug Kit, 1 Phase 350 A	2710202	1
PCB Assy, ZF1	2099161	1
SCR, 600 A, 1400 V	5060114	2
PCB Assy, DVDT	2071000	1
500 Ampere Units		
Fan, Axial, 115 Vac, 100 CFM	4520001	1
Fuse, 630 A, 700 V	7500124	1
Lug Kit, 1 Phase 500 A	2710203	1
PCB Assy, ZF1	2099161	1
SCR, 800 A, 1400 V	5080114	2
PCB Assy, DVDT	2071000	1

Item	Item No.	Qty
650 Ampere Units		
Fan, Axial, 115 Vac, 350 CFM	4520002	1
Fuse, 800 A, 700 V	7500125	1
Lug Kit, 1 Phase 650 A	2710204	1
PCB Assy, ZF1	2099161	1
SCR, 1500 A, 1400 V	5015214	2
PCB Assy, DVDT	2072000	1
800 Ampere Units		
Fan, Axial, 115 Vac, 350 CFM	4520002	1
Fuse, 1000 A, 700 V	7500126	1
Lug Kit, 1 Phase 800 A	2710205	1
PCB Assy, ZF1	2099161	1
SCR, 1500 A, 1400 V	5015214	2
PCB Assy, DVDT	2072000	1
1000 Ampere Units		
Fan, Axial, 115 Vac, 350 CFM	4520002	1
Fuse, 1250 A, 700 V	7500127	1
Lug Kit, 1 Phase 1000 A	2710206	1
PCB Assy, ZF1	2099161	1
SCR, 2800 A, 1400 V	5028214	2
PCB Assy, DVDT	2072000	1
1200 Ampere Units		
Fan, Axial, 115 Vac, 350 CFM	4520002	1
Fuse, 1600 A, 700 V	7500128	1
Lug Kit, 1 Phase 1200 A	2710207	1
PCB Assy, ZF1	2099161	1
SCR, 2800 A, 1400 V	5028214	2
PCB Assy, DVDT	2072000	1

7.4 Drawing List

This Chapter contains drawings that show outline dimensions, installation wiring, and printed circuit board component locations, as well as an overall schematic of the ZF1. These drawings are useful in installing and troubleshooting all ZF1 models. Table 7.2 lists the drawings for each model, Appendix provides simplified drawings in the order of their appearance. Drawings may also be downloaded from www.hdrpower.com.

Table 7.2 ZF3 Drawing List

Drawing Title	Drawing No.
Schematic, ZF1 – 60 - 1200 A	S2710007
Outline & Mounting, ZF1 – 60 - 225 A	M2710052
Outline & Mounting, ZF1 – 350 A, 500 A	M2710056
Outline & Mounting, ZF1 – 650 A	M2710058
Outline & Mounting, ZF1 – 800, 1000, 1200 A	M2710059

CHAPTER 8 – Warranty Policy

This chapter details the warranty policy of Ametek HDR Power Systems products. Ametek HDR Power Systems standard warranty policy is listed below. Note that the warranty policy for a particular job agreement may be different from the standard policy. When in doubt about warranty information, consult the factory.

8.1 Warranty

WARRANTY

AMETEK HDR warrants that the equipment delivered will be free from defects in workmanship and material for a period of five years from the date of shipment. AMETEK HDR will repair or replace, at AMETEK HDR's option, any part found defective during proper and normal use, provided that written notice of the nature of the defect is received by AMETEK HDR within the five year warranty period and that the customer returns the part to AMETEK HDR freight paid both ways. This warranty is not transferable by the initial end user.

AMETEK HDR MAKES NO OTHER WARRANTIES, EXPRESSED OR IMPLIED (INCLUDING, WITHOUT LIMITATION, MERCHANTABILITY, FITNESS FOR PURPOSE, OR AGAINST INFRINGEMENT OF ANY PATENT) EXCEPT AS EXPRESSLY PROVIDED HEREIN.

THE REMEDY OF REPAIR OR REPLACEMENT IS CUSTOMER'S SOLE AND EXCLUSIVE REMEDY AND WILL SATISFY ALL OF AMETEK HDR'S LIABILITIES, WHETHER BASED ON CONTRACT, NEGLIGENCE, TORT, PRODUCT LIABILITY, STRICT LIABILITY, OR OTHERWISE. IN NO EVENT WILL AMETEK HDR BE LIABLE FOR INCIDENT OR CONSEQUENTIAL DAMAGES, NOR IN ANY EVENT SHALL HDR'S LIABILITY EXCEED THE UNIT PRICE OF ANY DEFECTIVE PRODUCT OR PART.

8.2 In-house Repair Services

For all repair service at Ametek HDR Power Systems, you will need a Repair Material Authorization (RMA) number. Call **(614) 308-5500** and request a Repair Material Authorization (RMA) number. Please reference this number when making inquiries. Use the shipping address below for returns:

Ametek HDR Power Systems
503 Lakeview Plaza Blvd, Ste C
Worthington, Ohio, 43085
Attention: Repair Department/RMA #()

Prepay the shipment and include the following information if you are not using an Ametek HDR Power Systems Return Repair Tag: the Repair Material Authorization (RMA) number, part number, a description of the problem, contact phone number, a technical contact phone number (if different) and any additional comments. Put the Repair Material Authorization (RMA) number on the label.

Warranty Repairs: In addition to securing Repair Material Authorization (RMA) number, please supply the **System Serial number** (found on the Power Controller).

Non-Warranty Repairs: Secure a Repair Material Authorization (RMA) number from Ametek HDR Power Systems. The price for exchange or repair will be quoted when the unit can be evaluated. Once determined a quote will be provide, please include your hard copy purchase order (PO) for this amount, or fax your PO directly to the Sales Department at (614) 308-5506. Expedited services are available upon request.

8.3 Field Service Repairs

Repairs may be performed at your location. Please contact Ametek HDR Power Systems at (614) 308-5500 to discuss terms and conditions, to get the current service rates and to schedule field repairs at your location.

APPENDIX

Appendix A – ZF1 System Schematic

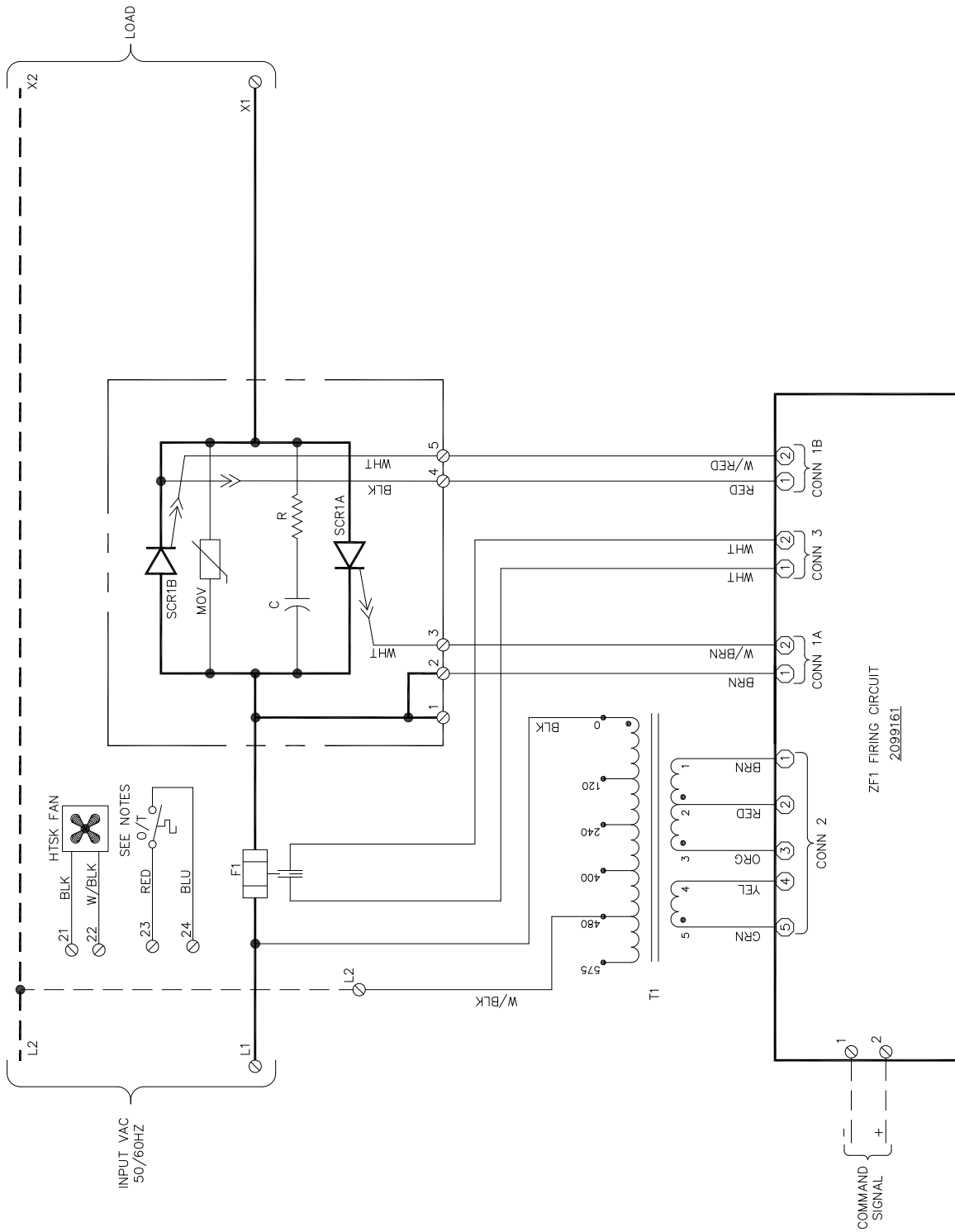

Note: Fans and Thermostats may not be included in certain models.

Appendix B – ZF1 60-225 A Outline

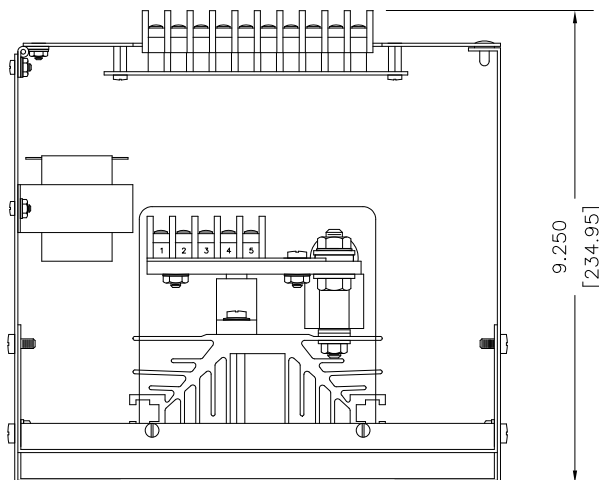
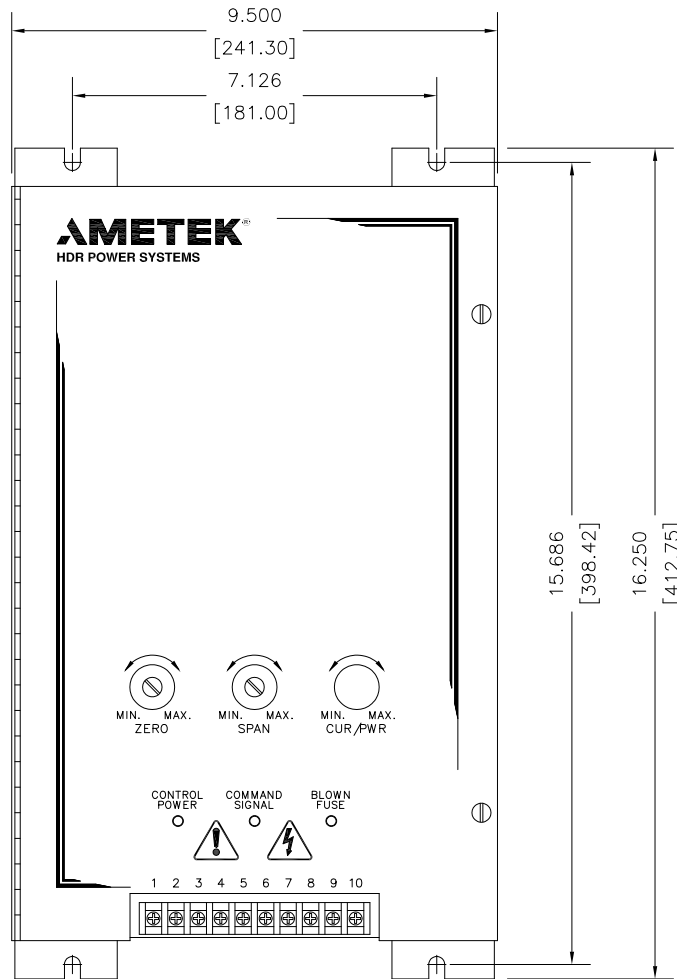

Appendix C – ZF1 350-500 A Outline

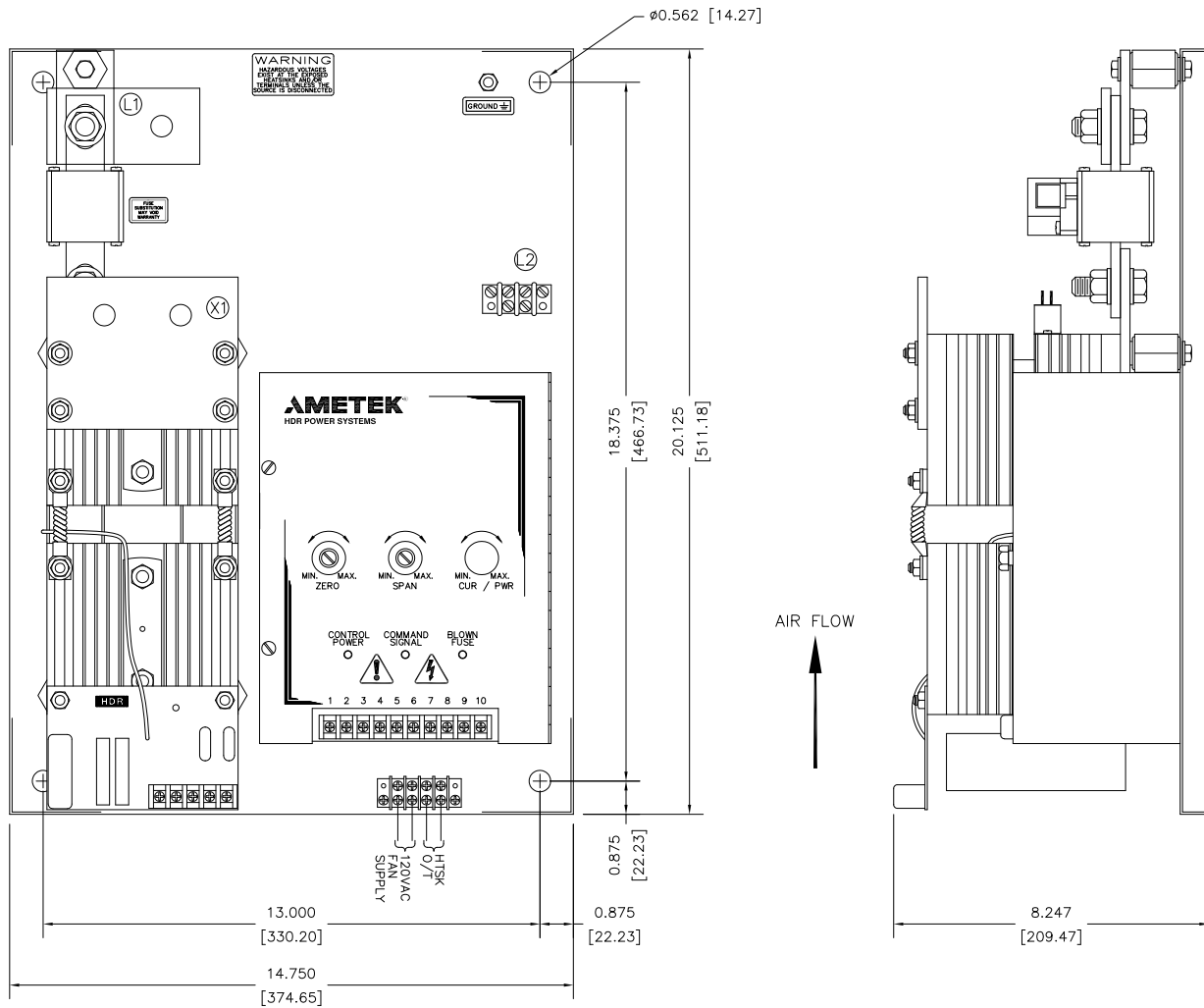

Appendix D – ZF1 650 A Outline

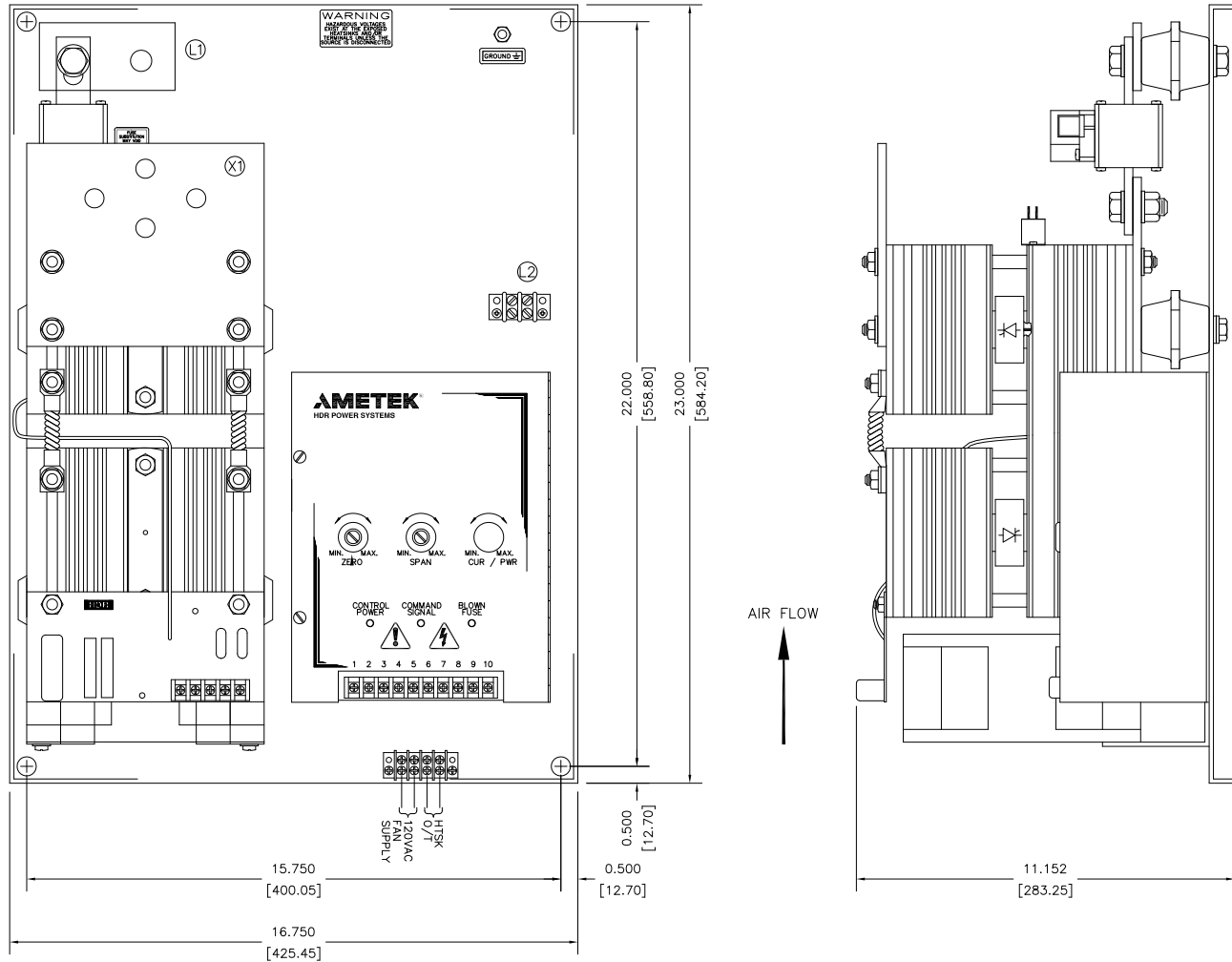

Appendix E – ZF1 800-1200 A Outline

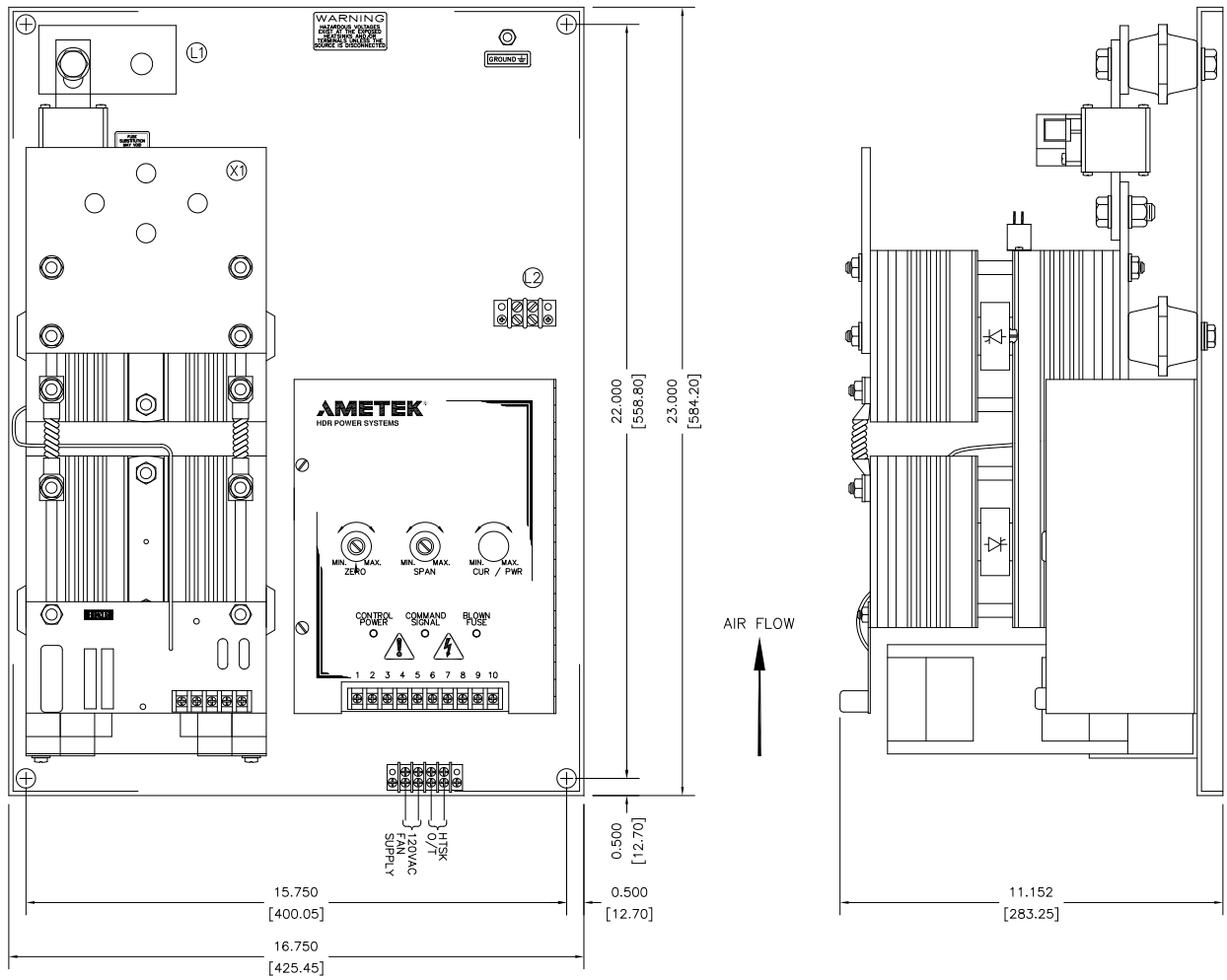

Appendix F – Declaration of Conformity



EC DECLARATION OF CONFORMITY

WE: **AMETEK HDR POWER SYSTEMS**
503 Lakeview Plaza Blvd, Ste C
Worthington, Ohio, 43085 - USA

Declare under our sole responsibility that the products listed below and bearing the CE label:

Type: SCR power controllers with the following model designations and current ratings:

ZF1, ZF2, ZF3, PF1, PF3 - 15, 25, 40, 60, 70, 90, 120,
180, 225, 350, 500, 650, 800, 1000 and 1200A.
SHZF1, SHPF1 - 15, 30, 40, 60, 70, 90 and 120A
SHZF2, SHZF3, SHPF3 - 15, 25, 30, 60, 90, 120, 180 and 225A
SCZF1, SCPF1 - 15, 25, 40 and 65A
All applicable options

To which this declaration relates is in conformity with the technical requirements of the following documents:

Title: Low-voltage switchgear and control gear	No. IEC 947-5-1 Year: 1990-03
Low Voltage Directive	No. IEC 73/23/EEC Year: 1973-02
Degrees of protection provided by enclosures (IP Code):	No. IEC 529-2nd Edition Year: 1989-11
Electromagnetic Compatibility	No. IEC89/336/EEC Year: 1989-05

Warning
All phase-fired (PF) controllers will require line filters and possibly shielded cables to meet the EMC requirements.

(Environmental protection classification IP00 - for mounting inside an enclosure)

Note: Characteristics are according to mfg specifications.

Name: Steve Wetta

Title: Director of Engineering

Date: July 21, 2015

Signature:

Declaration written in accordance with I.S.O. - IEC/22 Guide

Note: Certification performed on November 9, 2000 and revision is address change only

Notes:



503 Lakeview Plaza Blvd, Ste C
Worthington, Ohio, 43085 USA