

**60-1200 Amperes
Three-phase
Phase-fired**

SCR POWER CONTROLLER

Instruction, Operation and Maintenance Manual

Number: 9100034
Revision 3

AMETEK[®]
HDR POWER SYSTEMS

**530 Lakeview Plaza Blvd, Ste C
Worthington, Ohio, USA 43085**
Toll Free: 1-888-PWR-CNTL (797-2685)
Phone: 614-308-5500
Fax: 614-308-5506
Web: www.hdrpower.com

This manual applies to all Model PF3 SCR Power Controls. Former PF1/PF3 manual – 9100014 has been replaced with this manual.

For the support representative nearest you, please call Ametek HDR Power Systems main office at (614)-308-5500.

Revision 1	September 2014	Initial Release
Revision 2	July 2015	Revised Address
Revision 3	Aug 2022	General Revision

TABLE OF CONTENTS

IMPORTANT SAFETY INSTRUCTIONS	1
CHAPTER 1 - DESCRIPTION.....	3
1.1 General Description	3
1.2 Application	3
1.3 Operation	3
1.4 Specification	3
CHAPTER 2 - OPTIONS	5
2.1 General	5
2.2 Option OC (Three-Phase Overcurrent Trip)	5
2.3 Option CL/OC (Current Limit/Overcurrent Trip)	5
2.4 Option CR/OC (Current Regulation/Overcurrent Trip)	5
2.5 Option PR (Power Regulation with Current Limit)	6
2.6 Option ER (Extended Ramp)	6
2.7 Option LG (Lug Kit)	6
2.8 Additional Options	6
CHAPTER 3 - INSTALLATION	7
3.1 Mounting the PF3	7
3.2 Input/Output Wiring	7
3.3 Fan Wiring (applicable to models rated 90 A and higher)	7
3.4 Wiring Overtemperature Contacts	8
3.5 Command Signal Input	8
3.6 Determining Line Frequency	9
3.7 Voltage Changeover	9
3.8 Options	10
CHAPTER 4 - OPERATION	13
4.1 General	13
4.2 Front Panel Indicators	13
4.3 Command Input Control	13
4.4 Remote Manual Control with a Potentiometer	14
4.5 Auto/Manual Control with a Controller and Remote Potentiometer	15
4.6 On/Off Control	16
4.7 Shutdown	17
4.8 Unbalance Alarm	17
4.9 Shorted SCR Alarm	19
CHAPTER 5 – OPTIONS SETUP	21
5.1 Option OC (Overcurrent Trip)	21
5.2 Option CL/OC (Current Limit/Over Current Trip)	21
5.3 Option CR/OC (Current Regulation/Over Current Trip)	22
5.4 Option PR	22
CHAPTER 6 - THEORY.....	23
6.1 Functional Description	23
6.2 Overview of the PF3	23
6.3 Digital Firing Control Circuit	23
6.4 Pulse-Train Firing	23
6.5 Phase-Lock Loop	23
6.6 SPAN and ZERO Controls	24
6.7 Voltage-Squared Feedback	24

6.8	Shut-down	24
6.9	Soft-Start Circuit	24
CHAPTER 7 – TROUBLESHOOTING		25
7.1	Customer-Service Program	25
7.2	Troubleshooting Typical Symptoms	25
7.3	Static Precautions when Servicing	25
7.4	Environmental Problems	26
7.5	Input Power and Load Connections	26
7.6	Correcting Troubles in the PF3 Itself	27
CHAPTER 8 - SERVICE.....		29
8.1	Communication Procedures	29
8.2	Spare Parts Orders – Routine or Emergency	29
8.3	Spare Parts List	30
8.4	Drawing List	31
CHAPTER 9 – WARRANTY POLICY		33
9.1	Warranty	33
9.2	In-house Repair Services	33
APPENDIX.....		35
	Appendix A – System Schematic	35
	Appendix B – 60-225 A Outline	36
	Appendix C – 350-500 A Outline	37
	Appendix D – 650 A Outline	38
	Appendix E – 800-1200 A Outline	39
	Appendix F – Declaration of Conformity	40

TABLE OF CONTENTS

Par.	Title	Page
------	-------	------

ILLUSTRATIONS

Figure 3.1	Fan and Thermostat Connections	8
Figure 3.2	Isolated/Non-Isolated Switches	9
Figure 3.3	T1, T2 Transformer Connections	9
Figure 3.4	Current Transformer Connections	10
Figure 3.5	Typical PF3 Line and Load Connections	11
Figure 4.1	Control Panel	13
Figure 4.2	Process Controller Input Connections	14
Figure 4.3	Remote Control with a Potentiometer	15
Figure 4.4	Auto/Man Control with Controller and Remote Potentiometer	16
Figure 4.5	On/Off Control	16
Figure 4.6	Shutdown Control	17
Figure 4.7	Unbalance Alarm Board	18
Figure 4.8	Shorted SCR Alarm Board	19
Figure 4.9	Unbalance Block Diagram	20
Figure 5.1	Current Limit/Trip Board	21
Figure 6.1	AC Switch and SCR On-time	23

TABLES

Table 1.1	PF3 Model Number Breakdown	3
Table 1.2	General Specifications of PF3 Models	4
Table 3.1	Wire Size Information	7
Table 3.2	Transformer Voltage Wiring	10
Table 7.1	Troubleshooting Chart (Symptoms and Solutions)	27
Table 7.2	Torque Specifications	27
Table 8.1	PF3 Spare Parts List	30
Table 8.2	PF3 Drawing List	31

IMPORTANT SAFETY INSTRUCTIONS



WARNING

Observe all warnings and cautions in this manual. Failure to do so may result in serious injury or death.

Refer all service to properly trained and qualified service personnel. Never work alone.

Lethal voltages exist on exposed heat sinks even if the power controller is turned off. Remove power and lock out power before attempting any service.

SAVE THESE INSTRUCTIONS

This manual contains important safety instructions that must be followed during the installation and maintenance of the SCR Power controller. Read this manual thoroughly before attempting to operate this Power controller.

An appropriate branch circuit fused disconnect or circuit breaker with this Power Controller is required to ensure the safety of operating personnel.



CAUTION

HAZARDOUS VOLTAGES exist at the Power Controller Heat Sinks and at the Load, **AT ALL TIMES**, when input voltage is connected. This condition exists even when the Power Controller is set to deliver zero output.

Printed circuit boards contain sensitive components that can be damaged by electrostatic discharge (ESD). Observe precautions for handling electrostatic sensitive devices. Reference Maintenance and Troubleshooting (Chapter 7) of this manual for details

In case of fire, use a dry chemical fire extinguisher to put out the fire. Using a liquid fire extinguisher may cause electric shock.

The SCR Power Controller makes use of components dangerous for the environment (electronic printed circuit boards, electronic components). The components removed must be taken to specialized collection and disposal centers.



CHAPTER 1 - Description

1.1 General Description

The PF3 is a Three-phase, phase-fired power controller, and can operate with a wide variety of input signals and line voltages up to 575 Vac and currents ranging from 60 through 1200 amperes. The PF3's output voltage is proportional to its input signal. The PF3 features pulse-train firing which provides high immunity to possible SCR firing disturbances, and phase-lock loop circuitry which ensures line frequency synchronization. Other features are input isolation from ground, soft-start, and automatic restart circuitry. Terminals are provided to permit connection of a variety of external control methods. A more detailed description of the features mentioned above is provided in Chapter 6 of this manual.

1.2 Application

Phase-Fired SCR Power Controllers provide infinitely variable firing angles for precise control of three-phase power to resistive or inductive loads. This precise control is essential for transformer coupled loads or loads with great resistance changes due to temperature or start-up. Phase-Fired units may also be used on straight resistive loads as well, but the lower power factor and higher harmonics may present a problem to other equipment mounted nearby. A zero fired model would be a better choice.

1.3 Operation

The PF3 accomplishes power control by the switching action of a pair of inverse-parallel power SCRs. The switching, or gating, of the SCRs is controlled by a digital firing control circuit synchronized "in phase" with line frequency (either 50 or 60 Hz). A soft-start (approximately a 12 cycle ramp) feature is standard that allows the Power Controller to fire into the primary of a transformer or to control power to heating elements which have a large resistance change during start-up. The output may be adjusted by the on-board multi-turn potentiometers or by a voltage or current signal from a process controller. ZERO and SPAN controls allow the user to calibrate the SCR unit's output to the process command signal. Terminals are available for connection of a remote manual potentiometer.

1.4 Specification

Specifications for the PF3 SCR power controller are given in Tables 1.1 and 1.2.

Table 1.1 PF3 Model Number Breakdown

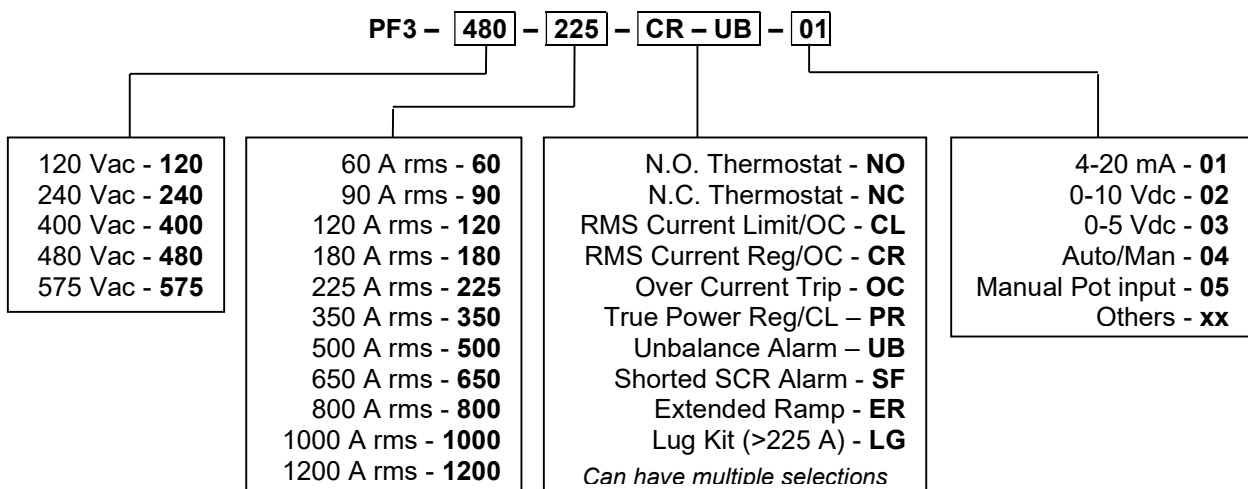

NOTE: N.O. Thermostat is included in current ratings above 60 A.

Table 1.2 General Specifications of PF3 Models

Input line voltage: *	120, 240, 400, 480, or 575 Vac, +10%, -15% , Three-phase		
Line frequency: *	50 or 60 Hz		
Current rating: *	As indicated by model number (refer to Table 1.1)		
Thermostat contact rating:	120 Vac, 5 A; resistive		
Input Signal:			
Non-isolated	0 to 1.5 V (min); 0 to 10 V (max)		
Isolated	0 to 6 mA (min); 0 to 20 mA (max)		
Control methods:	1. Potentiometer, 5 k Ω , 1/2 watt (Customer-supplied). 2. Dry contact closure (customer-supplied). 3. Temperature or process controller**		
Control signal input impedance:			
Non-isolated input	1500 Ω		
Isolated input	500 Ω		
Control signal isolation:			
From SCRs	2,500 Vac		
From ac power input lines	2,500 Vac		
From chassis	500 Vac		
Power output:			
Voltage regulation	Voltage Squared		
Power output linearity versus control signals input	+2% (Non-isolated) +5% (Isolated)		
Power SCRs protection:			
Current surge	Subcycle I ² T semiconductor fuse.		
Transient voltage spikes (dv/dt)	Metal Oxide Varistor (MOV) and R-C snubber across each SCR pair; all SCRs have PIV rating of 1,400 V.		
SCCR Rating	100kA		
Miscellaneous:			
Phase-firing timebase	0 ° to 180 ° conduction per SCR		
Controls:	ZERO and SPAN potentiometers; 10-turn, screwdriver-adjustable.		
Approvals	UL/cUL (E151547), CE		
Fan-cooling power (as applicable):			
For 90 A through 225 A units	0.42 amperes, 50 VA (50 Hz) 0.38 amperes, 46 VA (60 Hz)		
For 350 A through 500 A units	0.63 amperes, 76 VA (50 Hz) 0.57 amperes, 69 VA (60 Hz)		
For 650 A through 1200 A units	4.2 amperes, 504 VA (50 Hz) 3.6 amperes, 432 VA (60 Hz)		
Ambient Temperature range:			
Environment	32 °F to 122 °F (0 °C to 50 °C) surrounding air Pollution degree 2, Overvoltage Category III		
Storage	14 °F to 158 °F (-10 °C to 70 °C)		
Weight per unit:	Current Rating	lbs	kg
	60 through 225 A	47	18.2
	350, 500 A	60	27.3
	650 A	126	57.3
	800, 1000, 1200 A	231	105
Outline and mounting:	See appropriate drawing in Appendix		

* Specify with order

** If you will be using temperature/process controller, specify its output; e.g., 4-20 mA, 0-10 Vdc, 2-10 Vdc, etc. with your order.

NOTE: The PF3 should be tested or operated with an adequate load since an open output will have line voltage at the load connections.

CHAPTER 2 - Options

2.1 General

Several options are available from Ametek HDR Power Systems, and are described below. Most options require current transformers (CTs), which are optional. On models rated from 60 through 225 amperes the CTs are mounted in the controller and on models rated from 350 amperes and higher, the CTs are shipped separately.

2.2 Option OC (Three-Phase Overcurrent Trip)

The Three-Phase Overcurrent Trip Option (OC) provides circuit protection from output current overloads by serving as a fast-gate shutdown. (Option OC functions similar to an electronic fuse.) Trip point is adjustable from 30% to 200% of the SCR Power Control's current transformer rating. Current transformers on the SCR Power Control's output lines allow Option OC to monitor instantaneous peak current. When the peak current level exceeds the preset trip level, SCRs are gated off, and the load current is shut down within 1/2 cycle. The TRIP RESET pushbutton must be manually reset to resume operation.

Another feature of the overcurrent trip is an automatic reset. This is included with the current limit and current regulation. Open the unit and locate the auto reset switch and reset pushbutton. With this switch in the on position, the unit will continue to reset until the fault clears. If in the off position, the unit will remain shut off until the reset PB is operated. The auto reset switch will always be in the off position unless specified on the order.

The overcurrent trip option includes a Form C relay output and provisions for a remote overcurrent reset push button. The relay output terminals are 39 and 40 for the N.C. and 40 and 41 for the N.O. The remote reset terminals are 37 and 38. Reference Figure 5.1.

2.3 Option CL/OC (Current Limit/Overcurrent Trip)

The Three-Phase Current Limit Option (CL) prevents the output current of an SCR Power Control from exceeding a preset maximum current level, as determined by the current limit control setting (30% to 125%). This option also includes an OC trip with Form C relay output contact and terminals for connection of a remote OC reset pushbutton. The current limit adjustment is on the front of the unit, while the overcurrent trip adjustment is located on the current regulation PCB on the inside of the unit.

A current transformer monitors the true RMS current, and feeds the information to Option CL, which limits the true RMS current regardless of the process control signal. Current Limit is adjustable from 30% to 125% of the CT rating.

2.4 Option CR/OC (Current Regulation/Overcurrent Trip)

The Current Regulation option is much like the Current Limit. It includes an overcurrent trip feature, but regulates the RMS current rather than limiting it. The adjustment range is 30 to 125% of the unit's rating for the current regulation and 30 to 200% for the overcurrent trip. This option also includes an OC trip with Form C relay output contact and terminals for connection of a remote OC reset pushbutton. The current regulation adjustment is on the front of the unit, while the overcurrent trip adjustment is located on the current regulation PCB on the inside of the unit.

The Three-Phase Current Regulation Option (CR) compares the feedback signal to the control signal, so the line current will be linear to the control signal, and regulated to maintain a constant level at the controller output despite load changed. Current regulation is adjustable from 30% to 125% of the CT rating.

2.5 Option PR (Power Regulation with Current Limit)

This option is for applications where it is desirable to regulate the true power instead of the RMS current. This option also includes a RMS current limit as a safety feature. The Power Regulation control is on the front of the unit while the Current Limit control is inside on the Power Regulation PCB. The Three-Phase Power Regulation With Current Limit Option (PR), compares the feedback signal to the control signal, so the output power will be linear to the control signal, and regulated to maintain a constant power level at the controller output despite line and load changes. Current limit holds the current to a preset maximum limit, and is adjustable from 30% to 125% of the full rated current transformer rating.

2.6 Option ER (Extended Ramp)

The options limits the rate at which the output can increase to prevent high inrush currents with transformer coupled loads or high cold-to-hot resistance ratios such as tungsten heating elements. The rate of increase is limited to approximately 100% over four seconds. The standard extended ramp time is 12 cycles.

2.7 Option LG (Lug Kit)

Option LG will provide compression lugs for the 350-1200 A Power Controllers.

2.8 Additional Options

The options described above are the ones most commonly used. Additional options are available. For more information, contact Ametek HDR Power Systems.

CHAPTER 3 - Installation

3.1 Mounting the PF3

Determine the voltage and current ratings from the nameplate of the unit (refer to Table 1.1). Then determine space and mounting hole requirements by referring to the outline drawing (at the Appendix) that applies to your model's current rating. Mount the unit so the line and load connections are at the top and ensure that upward airflow over the heat sink fins is unrestricted. On high current models, allow adequate clearance for routing the relatively large diameter input and output lines.

3.2 Input/Output Wiring

Using appropriately sized and insulated conductors for the voltage and current ratings of your model, make connections as shown in Figure 3.3. (Refer to Table 3.1 for wire size information). Torque specifications of bolted connections can be found in Table 7.2.

A ground wire is required for proper operation. Use a 10 AWG or larger wire.

NOTICE	
Use copper conductors rated 75 °C minimum for all model current ratings.	
The PF3 is phase-rotation insensitive. That is, three-phase input power can be connected in any sequence to terminals L1, L2, and L3, and will not cause an out-of-phase condition.	

The fuses included are NOT meant for over current protection, separate branch circuit protection is required.

WARNING	
	Branch circuit overcurrent protection required is to be provided in accordance with the national and local codes of the inspecting authority.

On the “internal” side of the PF3, the wire from L2 should connect to the appropriate tap of transformer T1 and T2, depending on the line voltage to be used. Check the T1 and T2 connection by opening the PF3 cover; T1 and T2 terminal voltages are clearly marked. Reference Chapter 3.7.

Table 3.1 Wire Size Information

Model	Size Wire/Cable
60 A	8 to 0 AWG
90 A	8 to 0 AWG
120 A	8 to 0 AWG
180 A	6 to 250 MCM
225 A	6 to 250 MCM

3.3 Fan Wiring (applicable to models rated 90 A and higher)

PF3 models rated 90 A and higher with cooling fans require 120 Vac power which must be supplied by the customer. Fan power should be connected to terminals 21 and 22 as shown in Figure 3.1. Refer to Table 1.2 for fan power requirements by model.

The PF3 terminals available for the 120 Vac fan connections are shown Figure 3.1 and in the schematic in Appendix A. Optional 220 Vac fans are available.



CAUTION

The application of fan power should precede, or coincide with, the turn-on of the line voltage source that is to be controlled by the disconnect. How this is accomplished and ensured is up to the customer.

3.4 Wiring Overtemperature Contacts

Normally-open (N.O.) heat sink thermostats are standard on all fan-cooled models (rated 90 A and higher). These thermostats, which close on high heat sink temperature (200 °F), may be used to initiate an alarm, shunt trip, or other device for SCR protection. Thermostat connections are on terminals 23 and 24 as shown in Figure 3.1.

If desired, normally-closed (N.C.) contacts may be substituted for the normally-open (standard). Heat sink thermostats are optional on units with current ratings lower than 90 amperes and can be ordered with either N.O. or N.C. contacts.

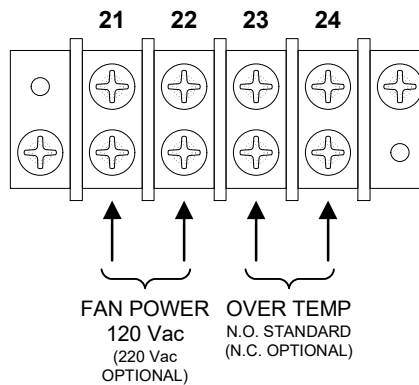

Figure 3.1 Fan and Thermostat Connections

3.5 Command Signal Input

HDR's Phase-Fired SCR Power Controllers have the capability of having either an isolated current or non-isolated voltage Command Signal input. The standard input impedance is 500 ohms for isolated and 1500 ohms for non-isolated.

All units are equipped with DIP switches, select "isolated" position for a 4-20 mA command signal and "non-isolated" for a voltage input such as 0-10 V dc. See Figure 3.2.

The isolated input works best with an offset Command Signal such as 4-20 mA; however, it will work with both offset and zero based Command Signals. Zero based Command Signals may have a small amount of non-linearity (input to output) at the low end. This should not be a problem on closed loop systems.

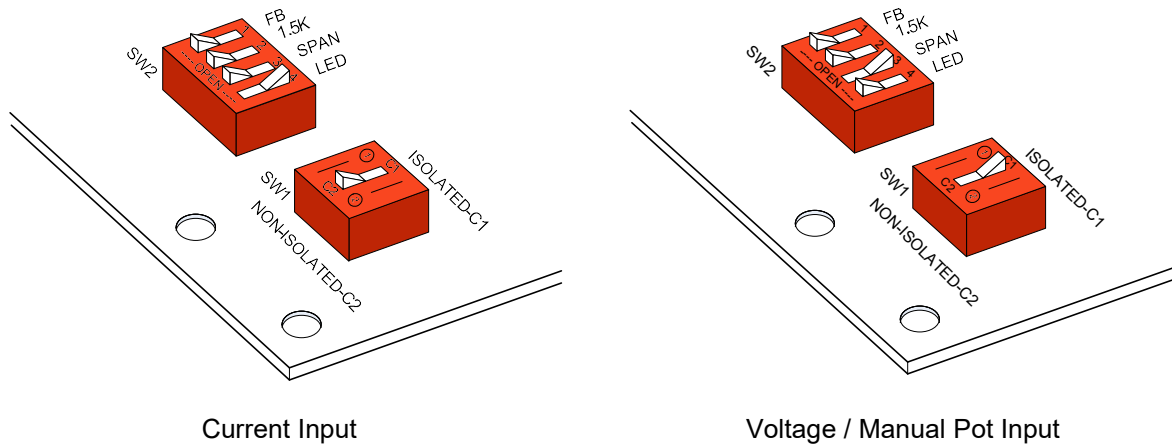



Figure 3.2 Isolated/Non-Isolated Switches

3.6 Determining Line Frequency

The PF3 is designed to operate on either 50 or 60 Hz. Usually the PF3 is shipped for 60 Hz operation, unless otherwise ordered. The PF3 can be set for either ac line frequency by selecting 50 Hz or 60 Hz on SW3 on the control board on the inside front door.

3.7 Voltage Changeover

On occasion, customers may wish to operate a PF3 SCR Power Controller on line voltages other than what was specified when originally ordered. The PF3 may be changed to accept a wide range of line voltages (120, 240, 400, 480, 575 Vac), so long as the load current does not exceed the PF3's current rating. This is accomplished by performing the procedure described below.



WARNING

Voltage changeover should be performed by qualified personnel only. Always remove power and properly lock out power to the unit before attempting any service.

Using the system schematic (located in the Appendix) as reference, perform the voltage changeover procedure as follows.

1. Open the SCR power controller, and locate transformer T1 and T2. The primary side of T1 transformer will contain two wires (one black, the other white and black), the primary side of T2 will contain two wires (one red the other yellow). Refer to Figure 3.3.

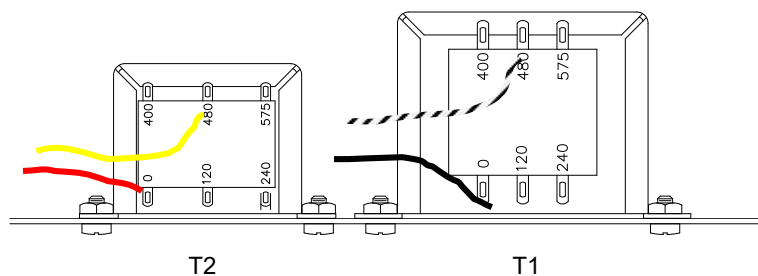

Figure 3.3 T1, T2 Transformer Connections

- Unsolder the Black/White wire on T1 from the voltage tap, and resolder it to the tap desired, as shown in Table 1. Unsolder the Yellow wire on T2 from the voltage tap, and resolder it to the tap desired, as shown in Table below. Route the wires so that they are physically located under the transformer terminals.

Table 3.2 Transformer Voltage Wiring

Desired Voltage	T1 White & Black Wire to	T2 Yellow Wire to
120	120	120
208	240	240
220	240	240
240	240	240
380	400	400
400	400	400
415	400	400
480	480	480
575	575	575

- Close the unit, and apply line power. The unit is now ready for operation on the line voltage selected. It is a good idea to identify the unit with a label or tag, noting that PF3 has been modified for line voltage other than what it was specified for. This may prevent accidental use on an incorrect line voltage in the future.

3.8 Options

Options, if ordered by the customer, have been installed and set up at the factory. However, if the current transformers (CTs) are shipped loose, they should be placed on the load lines when the load lines are connected (first step in Chapter 3.2), and wired as indicated on the schematic in Appendix A.

On the PF3 Phase 1 CT connects to terminals 31 and 32; Phase 2 CT connects to terminals 33 and 34; and Phase 3 CT connects to terminals 35 and 36. Reference Figure 3.4 and schematic in Appendix. If erratic control is noticed (power regulation only) reverse the current transformer secondary connections.

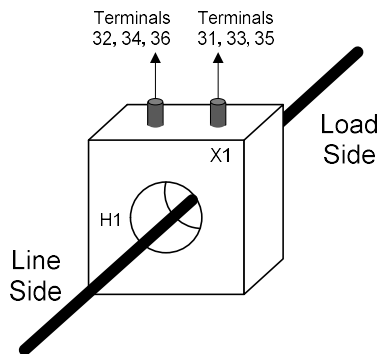
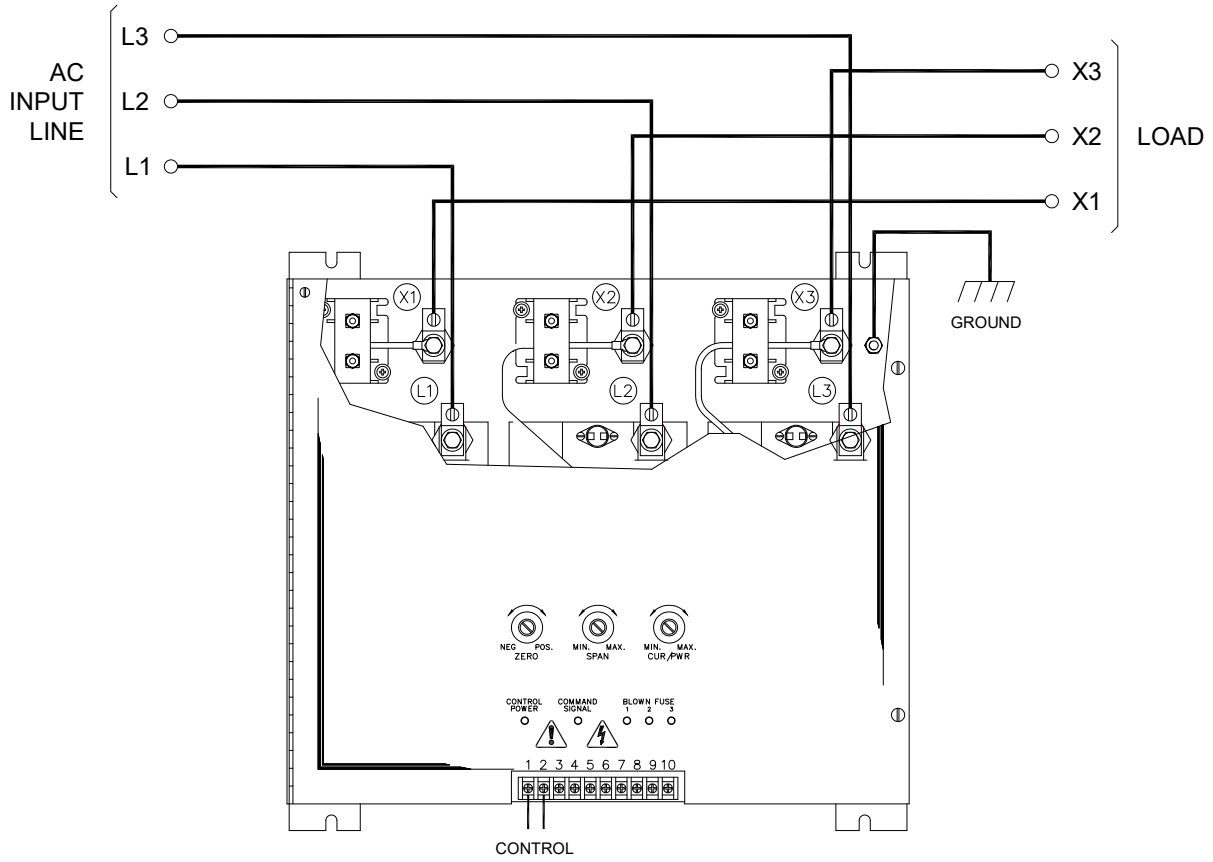

Figure 3.4 Current Transformer Connections



Note: Unit shown with optional CT's and CUR/PWR potentiometer.

Figure 3.5 Typical PF3 Line and Load Connections

CHAPTER 4 - Operation

4.1 General

This Chapter provides information necessary for proper setup and operation of various methods used to control the PF3.

- a. Front Panel indications
- b. Command input control
- c. Remote manual control with a potentiometer
- d. Auto/manual control with a controller and potentiometer
- e. On/off control
- f. Shutdown

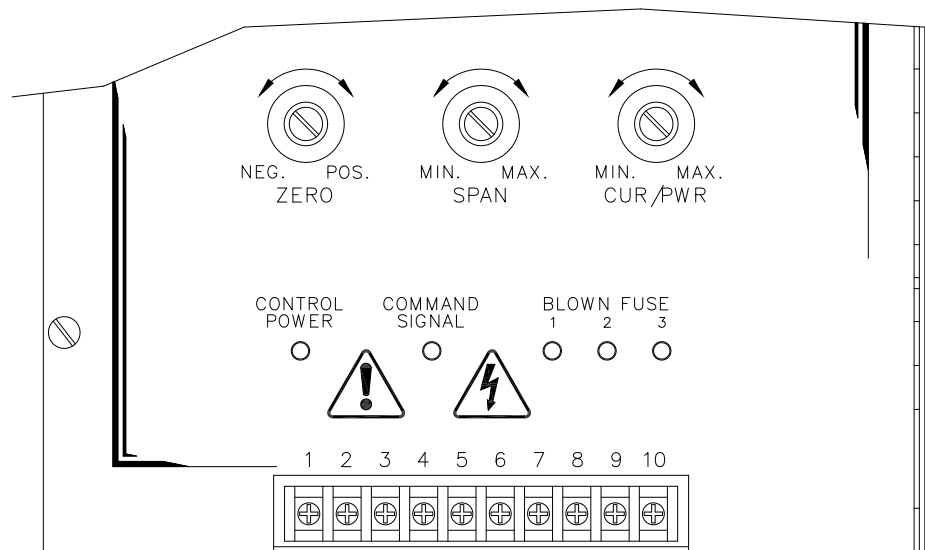

Figure 4.1 Control Panel

4.2 Front Panel Indicators

Control Power Indicator – A Red Light Emitting Diode (LED) located on the front cover of the unit signals when the control power is present.

Command Signal Indicator - The Command Signal Indicator is a green Light Emitting Diode (LED) located on the front cover of the unit. The brilliance of this LED will change with a current Command Signal. The brilliance increases with an increased Command Signal and decreases with a decreased Command Signal. The LED will not function with a voltage or manual input.

Blown Fuse Indicator - The Blown Fuse Indicators are yellow Light Emitting Diodes (LED) located on the front cover of the unit. There is one LED for each phase. Switches on each fuse controls the LED.

4.3 Command Input Control

The PF3 is calibrated at the Factory for the specified input type and normally does **NOT** need adjustment. However, should a setup be required use the following methods. Refer to chapter 3.5 for the Command signal input configuration.



WARNING - ELECTRIC SHOCK CAN KILL
HAZARDOUS VOLTAGES exist at the output terminals and at the load when the input voltage is connected. This condition exists even when the Controller is set to deliver zero output. Always remove power and properly lock out power to the unit before attempting any service, including the load.

- a. If Option CR or PR is installed, set the 10-turn CUR/PWR potentiometer to its mid-point.
- b. Set the **ZERO** and **SPAN** controls fully CCW (counterclockwise).
- c. Connect a voltmeter across terminals X1 and X3 of the PF3. Set the voltmeter range to measure full input voltage.
- d. Close the fused disconnect or circuit breaker to apply power to the PF3. Turn the Process controller on and set to demand zero power output.

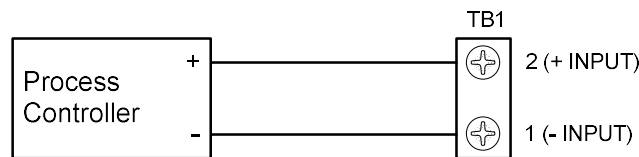

Figure 4.2 Process Controller Input Connections

- e. Adjust the **ZERO** control CW until the output just turns on, then turn the **ZERO** control CCW just to the point where the output voltage reading is zero.
- f. Set the Process controller to demand 100% output. Observing the voltmeter, adjust **SPAN** CW just to the point where the reading is below the maximum output voltage. Then adjust **SPAN** CW just to the point where the meter reading is at maximum.
- g. Repeat steps 4.3e and 4.3f as necessary, to ensure proper control adjustments have been made.
- h. Turn off the line power to the PF3 and disconnect the test equipment. The PF3 is now ready for automatic operation.
- i. If Option CR or PR is installed, adjust the **CUR/PWR** potentiometer CW until the output is limited to the desired level.

4.4 Remote Manual Control with a Potentiometer

Some applications only require a manual control input and not a closed loop input from a process controller. This potentiometer may be located on a remote panel near other controls related to the process being powered by the PF3. It may be calibrated to correspond to a percentage of rated power output, process temperature, or some other parameter. The potentiometer may be 500 Ω to 5 k Ω , and should be rated at 1/2 watt, minimum.

- a. With the power to the PF3 turned off, connect the potentiometer as shown in Figure 4.3. The CW position is the full power output position. Terminal TB1-5 is internally connected to a positive dc voltage source.

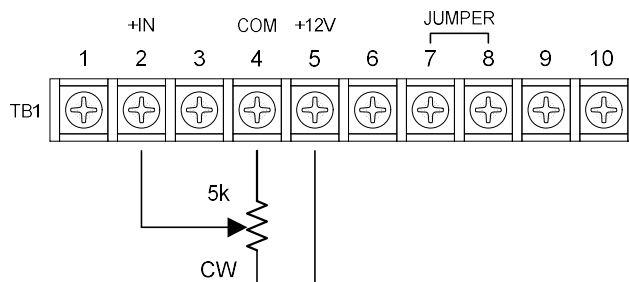

Figure 4.3 Remote Control with a Potentiometer

- b. If Option CR or PR is installed, set the 10-turn CUR/PWR potentiometer to its mid-point.
- c. Connect a voltmeter across terminals X1 and X2 of the PF3. Set the voltmeter range to measure the full output voltage.
- d. Set the **SPAN** control and remote potentiometer fully CCW.
- e. Close the fused disconnect or circuit breaker to apply power to the PF3. The unit should be energized, with no output.
- f. Adjust the **ZERO** control CW until the output just turns on, then turn the **ZERO** control CCW just to the point where the output voltage reading is zero.
- g. Set the **SPAN** control and remote potentiometer fully CW. The output should be full-on.
- h. Observe the voltmeter and slowly adjust the **SPAN** control CCW, just to the point where the output voltage reading is at maximum.
- i. If necessary, readjust **ZERO** with remote potentiometer fully CCW and **SPAN** control and remote potentiometer fully CW.
- j. Turn off the line power to the PF3 and disconnect the test equipment.
- k. If Option CR or PR is installed, adjust the **CUR/PWR** potentiometer CW until the output is limited to the desired level.

4.5 Auto/Manual Control with a Controller and Remote Potentiometer

On closed loop processes it may be desirable to be able to operate the unit manually. The SCR Power Controller has this capability designed into it. Connect the Command Signal, a Remote Manual control and an Auto/Manual switch in the Auto position. By switching to the Manual position, the Remote Manual control operates and the auto signal is disconnected.

With the power to the PF1 turned off, connect the switch, potentiometer, and controller as shown in Figure 4.4 and remove jumper from terminal TB1-7 and TB1-8. Install the **AUTO/MAN** switch in the same general location as the remote manual potentiometer. Note that the full CW position of the potentiometer is the full-power-output position.

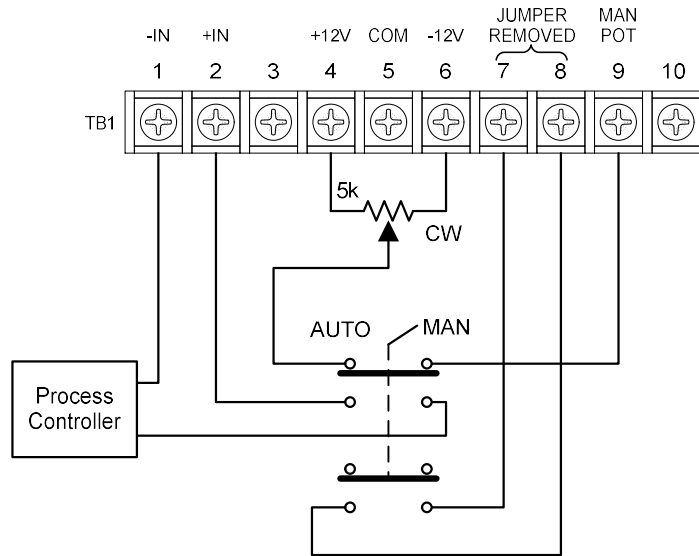

Figure 4.4 Auto/Man Control with Controller and Remote Potentiometer

Place the **AUTO/MAN** switch to **AUTO** and calibrate the system as described in steps 4.3b through 4.3k.

4.6 On/Off Control

Some applications require that a simple ON/OFF type control be used. The unit can be used in these simple applications. It can be connected for turn on by a contact closure.



WARNING

This method of control is not to be used with isolated inputs!

With the PF3 configured for non-isolated inputs and the power to the PF3 turned off, connect the system as shown in figure 4.5. A closed contact will turn on (enable) the PF3.

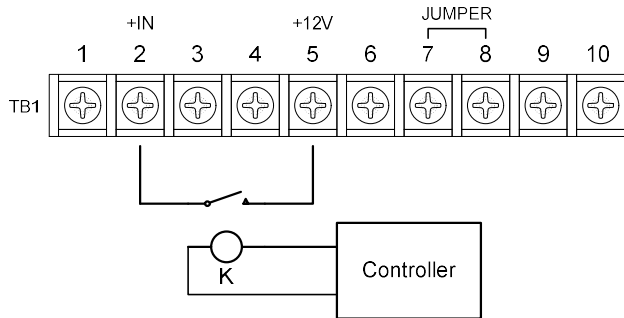
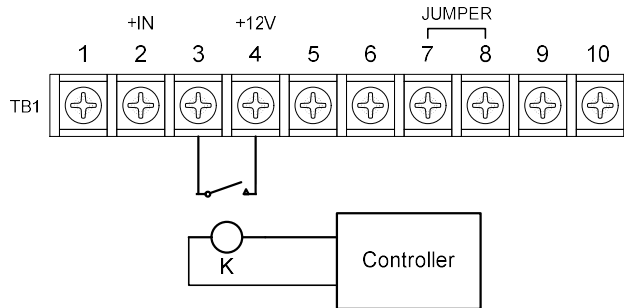

Figure 4.5 On/Off Control

Calibrate the system by performing the steps in 4.3. Note that zero power demand is accomplished by opening the contacts with the controller, and maximum power demand is present when the contacts are closed.

4.7 Shutdown

When it is necessary to shutdown or disable the output, it is a simple matter. Connect a dry contact closure between terminals 3 and 4 of the firing circuit as shown in Figure 4.6. A closed contact will disable the PF3 output.



**Figure 4.6 Shutdown Control
(Output Disabled By Contact Closure)**

4.8 Unbalance Alarm

The circuit contains three True RMS current converters that output three dc voltages that represent the rms ac currents. The logic circuit then selects the highest of the three load currents and computes a percentage of that current as determined by the DIP switch setting. The available settings are 97.5, 95, 92.5, 90, 87.5, 75 and 50%. The default setting is 87.5%. The two lower currents are then compared to this alarm setpoint. If either, or both are below this alarm value, then the green LED associated with that line will go out and after a short delay, the red LED and relay will energize.

If the lower two currents are above the selected setpoint, then all three green LEDs will be on, indicating a normal condition, and the red alarm LED and relay will not be energized.

Since current must be present to determine whether the three currents are equal, the alarm must be disabled when the controller approaches very low power levels. When the highest current falls below 15 to 20% of the current transformer's rating, the alarm is disabled, the amber "Insufficient Current" LED lights, the red LED and relay are disabled and the status of the green LEDs is indeterminate.

Selecting an appropriate percentage of load unbalance using the DIP switches is the only setting most users will ever need to make and might best be illustrated by the following example.

EXAMPLE

Assume a 3-phase, 120 amp controller is being used to control 12 heating elements of equal size with 4 elements connected in parallel of each leg and the controller is set at approximately 100 amps per leg. Each of the four elements on each leg draw approximately 25 amps each so that the loss of one element will drop the current to 75 amps or 75% of full current. The easiest way to select the alarm setpoint is to pick the percentage that is half way between 100% and 75%. In this case 87.5% would be appropriate.

To estimate the exact function of the circuit, assume that the exact currents on the three legs are 100 amps, 99.5 amps, and 99 amps (using a precise, true RMS meter). The circuit will select the highest current, 100 amps, and compute 87.5% of that value, or 87.5% amps. If one element of the 99.5 amp leg opens, the current on that leg will fall to about 74.6 amps. Since this will be below the 87.5 amps alarm setpoint, the circuit will signal an alarm condition. The actual current on the low leg that will trigger an alarm can always be calculated by measuring the three leg currents and multiplying the highest current by the percentage selected by the DIP switch. The circuit constantly recalculates the allowable current unbalance. If the command signal drops so that the highest current is 50 amps, the allowable low current would be 87.5% of 50 amps, or 43.75 amps. If one of the four heating elements fails, the current on that leg will fall to about 37.5 amps (75% of 50 amps) and the alarm will be activated.

Five diagnostic indicators are provided on the Unbalance Alarm to help determine the status of the load unbalance board. There are three green LEDs, one amber LED and one red LED. The three green LEDs indicate the three phase currents are above the alarm setpoint, the amber LED indicates that the line currents are insufficient to determine a load failure and the red LED indicates the alarm condition. Each LED is labeled on the board.

The relay output is on terminals 58 (N.O.), 59 (Common) and 60 (N.C.) as shown in figure 4.7. The relay is energized on alarm.

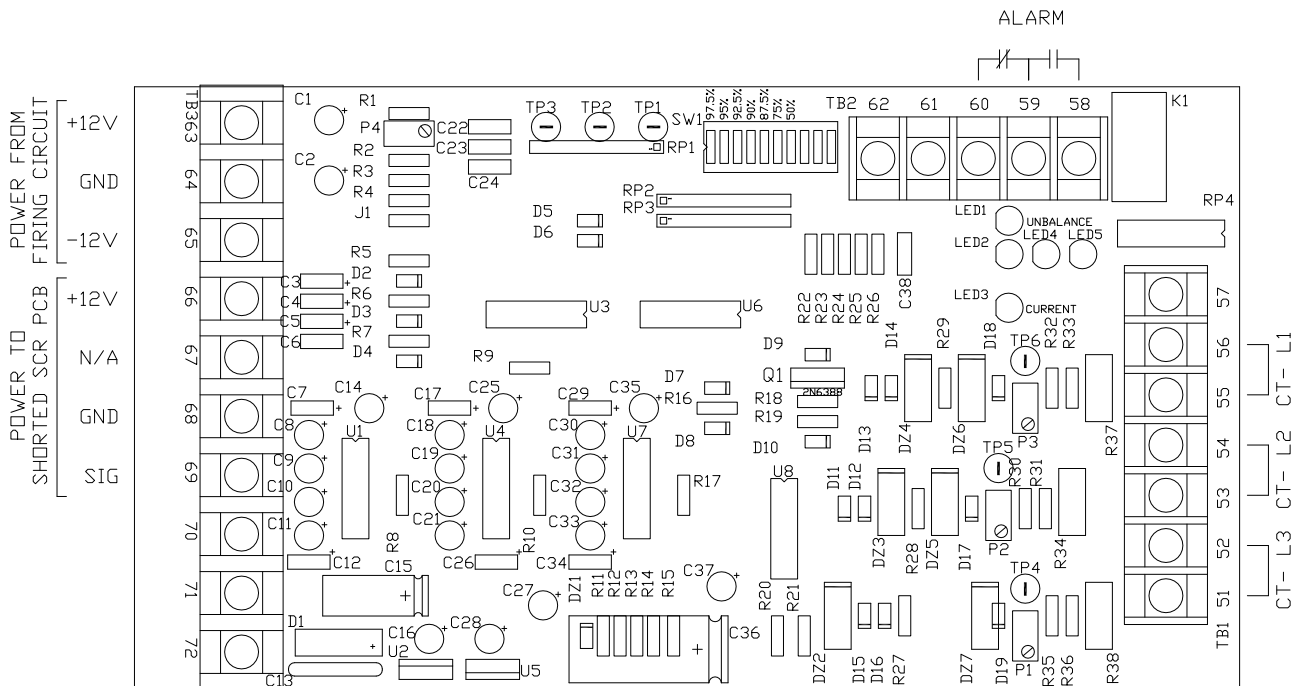

Figure 4.7 Unbalance Alarm Board

4.9 Shorted SCR Alarm

The Shorted SCR Alarm, monitors each of the 3 SCR pair's voltage drop and detects when an SCR is shorted. Four LEDs are provided to help you determine the operation of the SCRs. Three green LEDs are lit when the SCRs are not shorted. If an SCR shorts, the respective green LED will go out and the red alarm LED will light and the Form C relay will energize. The relay output is on terminals 81 (N.O.), 82 (Common) and 83 (N.C.) as shown in figure 4.9. The relay is energized on alarm. These are the only customer connections.

Typically the SCR Shorted Alarm board is a piggy-back board on the Unbalance Alarm and does not require any calibration. The Shorted SCR Alarm can be used with or without the Unbalance Alarm

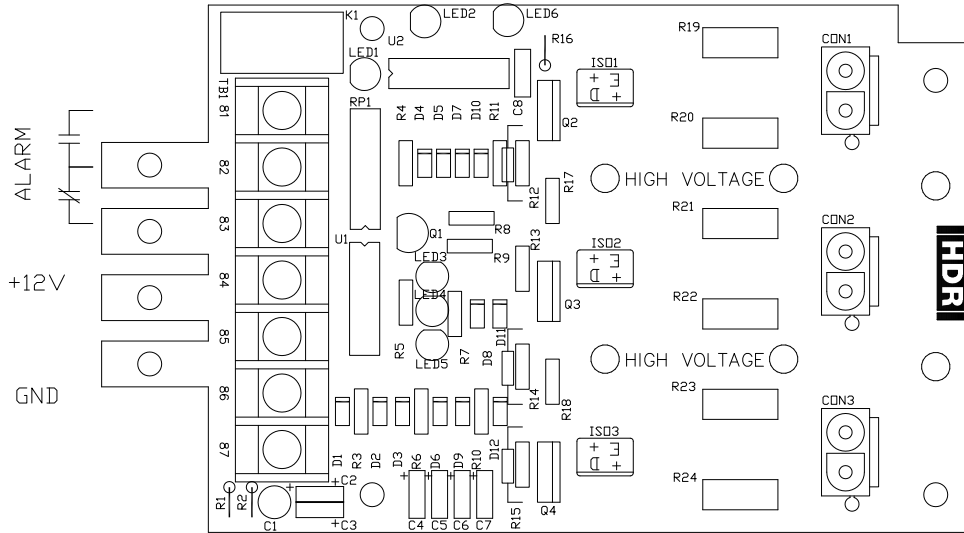

Figure 4.8 Shorted SCR Alarm Board

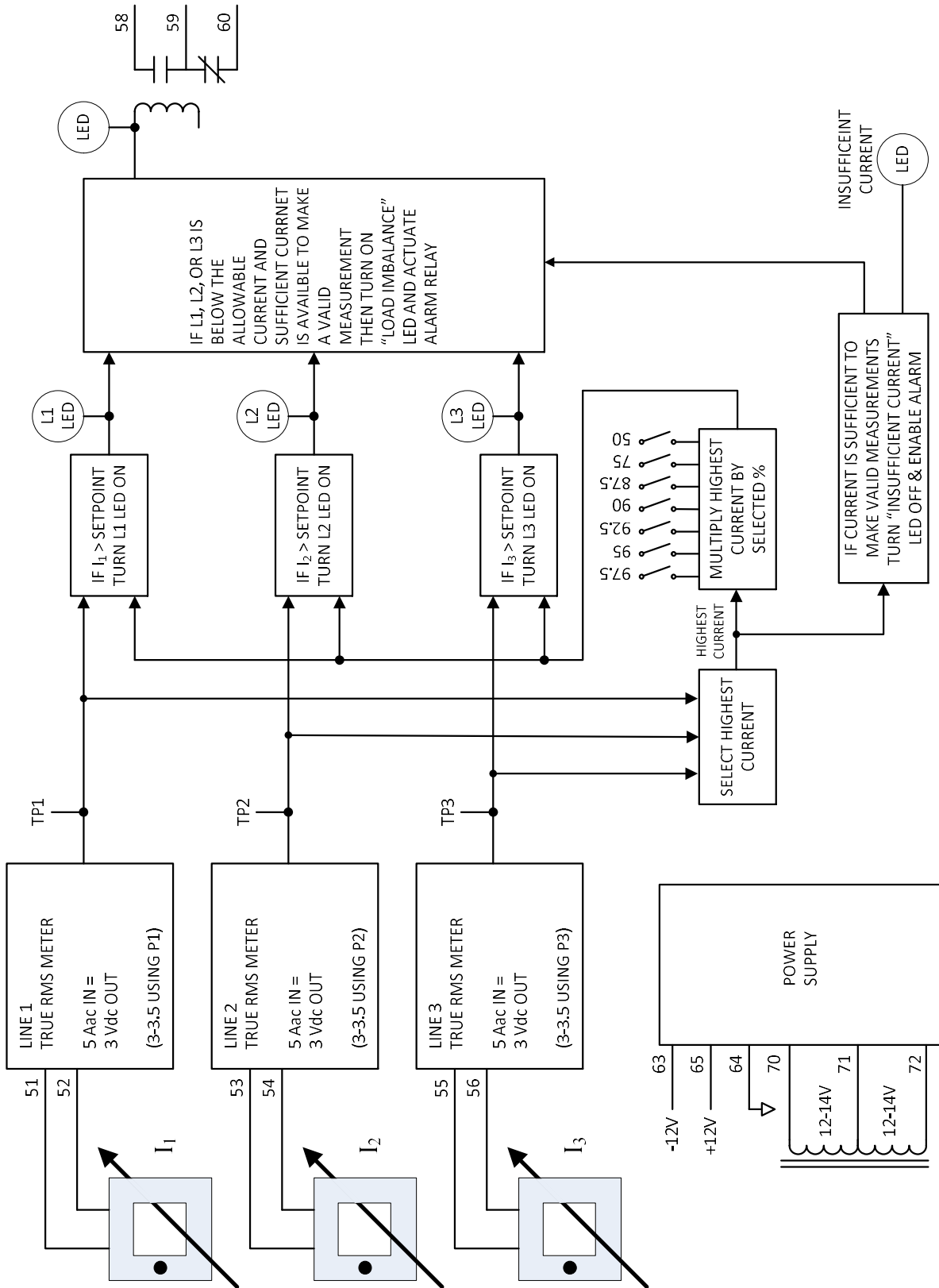

Figure 4.9 Unbalance Block Diagram

CHAPTER 5 – Options Setup

5.1 Option OC (Overcurrent Trip)

Refer to Chapter 4, and review the setup procedure for the ZERO and SPAN controls. Then adjust Option OC as follows:

- Adjust the OC (**CUR/PWR**) potentiometer fully CW.
- Adjust **ZERO** and **SPAN** as previously described in Chapter 4.
- With the power controller at full output, adjust OC (**CUR/PWR**) potentiometer CCW until the unit shuts off.
- Adjust the OC (**CUR/PWR**) potentiometer slightly CW.
- Momentarily press the RESET pushbutton on the Current Limit option PCB on the inside front door. The power controller should turn on.

5.2 Option CL/OC (Current Limit/Over Current Trip)

Refer to Chapter 4, and review the setup procedure for the ZERO and SPAN controls. Then adjust Option CL as follows:

- Set the TRIP LEVEL potentiometer fully CW.

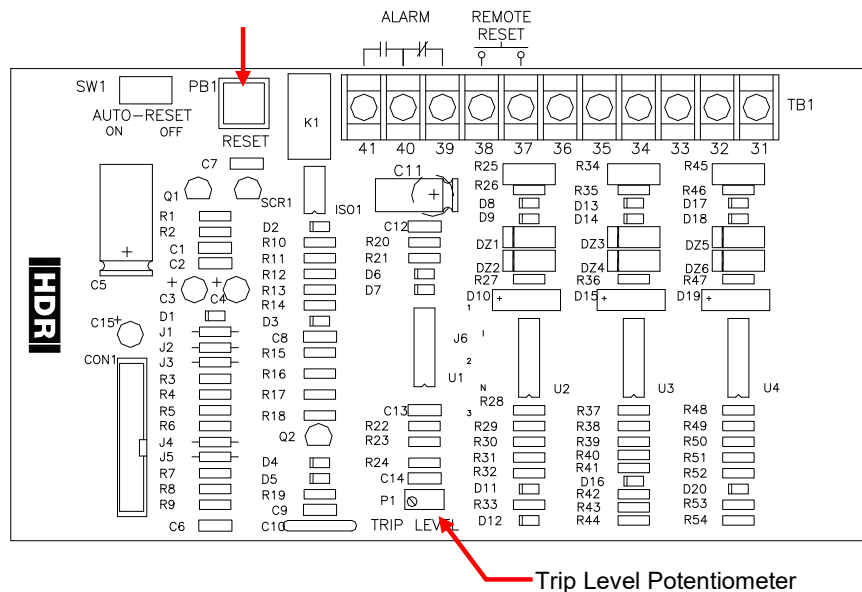

Figure 5.1 Current Limit/Trip Board

- Adjust the CURRENT LIMIT (**CUR/PWR**) potentiometer fully CW.
- Adjust ZERO and SPAN as previously described.
- Adjust CURRENT LIMIT (**CUR/PWR**) potentiometer full CCW.
- Increase the input control signal to demand full output
- Adjust the CURRENT LIMIT (**CUR/PWR**) potentiometer until maximum current level is reached.
- With the power controller at full output, adjust the TRIP LEVEL potentiometer CCW until the unit shuts off.

- h. Adjust the TRIP LEVEL potentiometer slightly CW.
- i. Momentarily press the RESET pushbutton on the Current Limit option PCB on the inside front door or remotely with a push button connected to terminals 33 & 34. The power controller should turn on.

5.3 Option CR/OC (Current Regulation/Over Current Trip)

Refer to Chapter 4, and review the setup procedure for ZERO and SPAN controls. Then adjust Option CR/OC as follows:

- a. Set the TRIP LEVEL potentiometer fully CW.
- b. Adjust the CURRENT REG (**CUR/PWR**) potentiometer fully CW.
- c. Adjust **ZERO** and **SPAN** as previously described.
- d. Adjust CURRENT REG (**CUR/PWR**) potentiometer full CCW.
- e. Set the input control signal to demand full output
- f. Adjust the CURRENT REG (**CUR/PWR**) potentiometer until full-scale current level is reached.
- g. With the power controller at full level, adjust the OC LEVEL potentiometer CCW until the unit shuts off.
- h. Adjust the OC LEVEL potentiometer slightly CW.
- i. Momentarily press the RESET pushbutton. The power controller should turn on.

5.4 Option PR

Refer to Chapter 4, and review the setup procedure for the ZERO and SPAN controls. Then adjust Option PR as follows:

- a. Adjust the PR and CL potentiometers fully CW.
- b. Adjust **ZERO** and **SPAN** as previously described.
- c. Adjust the PR (**CUR/PWR**) potentiometer fully CCW.
- d. Set the input control signal to demand full output.
- e. Adjust the PR (**CUR/PWR**) potentiometer until the maximum power level is reached.
- f. Adjust the CL potentiometer CCW until the maximum current starts to reduce.

CHAPTER 6 - Theory

6.1 Functional Description

The main function of the PF3 is to control the amount of power delivered to a load. The PF3 accomplishes this by controlling the portion of each input cycle for which power is delivered.

The SCR is either on or off and conducts in one direction when turned on. Because the SCR only conducts in one direction, two SCR's are connected in "inverse parallel" configuration, Figure 6.1. A small gate signal is applied to turn on the SCR. Once the SCR is turned on, it will remain On until the current through the SCR goes below the holding current level.

For Phase angle firing each pair of Inverse Parallel SCR's is turned on for a variable portion of the half-cycle that conducts. This advancing or delay of the firing angle will regulate the power and is used to control fast responding loads.

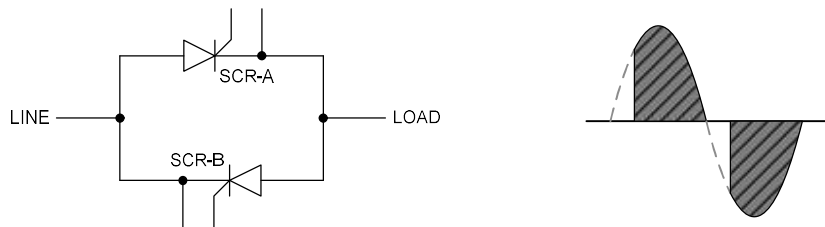

Figure 6.1 AC Switch and SCR On-time

6.2 Overview of the PF3

The following paragraphs provide a functional description of the digital firing control circuit, pulse-train firing, phase-lock loop, SPAN and ZERO controls, voltage-squared feedback, shutdown, and soft-start circuitry.

6.3 Digital Firing Control Circuit

Firing (gating) of the SCRs is controlled by a digital firing control circuit synchronized to the line frequency (50 or 60 Hz). The firing control circuit may be manually controlled by the built-in ZERO control or a remote potentiometer. Automatic control may be from a temperature or process controller that provides a demand-proportional low-level voltage or milliampere output signal. The firing control circuit may also be turned on and off by an external switch or relay contacts. (Chapter 4 discusses some external control methods.)

6.4 Pulse-Train Firing

The output of the PF3 to the SCRs consists of a pulse-train of approximately 17 kHz. This means that for every cycle of controlled output, the SCRs would receive approximately 142 trigger pulses, which will ensure constant gating during the "on" period of the PF3's output. This also ensures that the SCR is gated on in case of a mid-cycle turnoff.

6.5 Phase-Lock Loop

When the output of the oscillator is locked to the input signal, it is said to be "locked" in phase. The control voltage is such that the frequency of the voltage controlled oscillator is exactly equal to the frequency of the input signal. For each cycle of input there is one cycle of oscillator output. By this

method, the PF3's output will be held at 50 Hz or 60 Hz, depending on configuration. The input signal is filtered, then compared to the oscillator, improving noise immunity over conventional sync circuits.

6.6 SPAN and ZERO Controls

The ZERO and SPAN potentiometers are screwdriver adjustable. The center position of the ZERO control corresponds to zero bias and zero power output. The approximate zero setting can be found by rotating the control over its range, stopping near the midpoint of rotation. The precise zero setting can be found by observing the output level while rotating the control near the midpoint of rotation. From the midpoint to extreme CCW (counterclockwise) is the zero or negative region. Operating the control in this region, one can zero the output from the PF3 at any output level of a temperature controller or other external control device. From midpoint to extreme CW is the positive control region, whose extremes correspond to 0% and 100% power output, respectively, as manually adjusted.

The SPAN control is used as a final adjustment to set the PF3 output to precisely 100%, when the principal control device (external controller, external "manual" control or ZERO potentiometer) is set to demand 100% output.

6.7 Voltage-Squared Feedback

Voltage-squared feedback simulates power feedback. It is used to help maintain constant power delivered to the load when the line voltage changes and the load resistance remains constant.

6.8 Shut-down

The shutdown circuit provides a quick SCR shutdown signal. This is accomplished via a customer provided contact across terminal 3 and terminal 4. This removes the input signal to the comparator that tells the circuit when to gate the SCRs on. It also instantaneously turns off the SCR gating pulses.

6.9 Soft-Start Circuit

The PF3 includes a protective circuit, the soft-start circuit that limits the rate at which output voltage can rise. This protection is necessary to prevent large surge currents associated with transformers and similar loads when power is first applied to them. The circuit comes into play during startup or after a power interruption of several cycles' duration.

CHAPTER 7 – Troubleshooting

7.1 Customer-Service Program

Although service is seldom necessary, because of the inherent long-term reliability of solid-state components and conservative design, Ametek HDR Power Systems emphasizes customer satisfaction by maintaining a rapid-response and cooperative customer-service. If operational difficulties occur, Ametek HDR Power Systems will provide replacement parts or units quickly, courteously and efficiently. If servicing problems arise that are not within the scope of the following troubleshooting guide, service is readily available, as detailed in Chapter 8.

7.2 Troubleshooting Typical Symptoms

The PF3 is considered to be operating properly when its output voltage can be satisfactorily varied from 0% to 97% of the available input voltage by a control signal. Improper operation of the unit is usually indicated by one of the following symptoms:

- a. No output.
- b. Full output at all times, with no change resulting from a control signal change.
- c. Output variable from some intermediate value to maximum, but cannot be brought to zero.
- d. Output variable from zero to some intermediate value, but cannot be brought to maximum.

The symptoms listed may be caused by one or more of the following: an environmental problem, faulty input-power or load connections, and the PF3 itself. These possible causes should be investigated as described in Chapters 7.4 through 7.6.



WARNING - ELECTRIC SHOCK CAN KILL
HAZARDOUS VOLTAGES exist at the exposed heat sinks and at the load unless the line-source fused disconnect or circuit breaker is open or off. This is true even when the SCRs are turned off. Always remove power and properly lock out power to the unit before attempting any service is performed.

7.3 Static Precautions when Servicing

Servicing should be performed by qualified personnel only, following procedures described herein.



ATTENTION
Printed circuit boards contain sensitive components that can be damaged by electrostatic discharge (ESD). Observe precautions for handling electrostatic sensitive devices.

If troubleshooting indicates a need to replace a component on a printed circuit board or possibly the entire board, measures to prevent electrostatic discharge (ESD) damage must be taken.

- a. ALWAYS wear a wrist strap connected to ground through a 1-megohm resistor when working on printed circuit boards.
- b. Use soldering iron with a grounded tip.
- c. Use a non-static solder sucker (metallic) or solder removal braid.

- d. Transport static sensitive components in static shielding bags or rails. A new printed circuit board should be treated as a static sensitive device. A part completely installed on a board does not make the part static-safe.
- e. If possible, perform printed circuit board maintenance at a work station that has a conductive covering which is grounded through a 1-megohm resistor. If a conductive table top is unavailable, a clean steel or aluminum table top is an excellent substitute.
- f. Keep plastic, vinyl, Styrofoam or other non-conductive materials away from printed circuit boards. They are good static generators that do not give up their charge easily.
- g. Return goods to Ametek HDR Power Systems in static-safe packaging. This will limit further component damage from ESD.
- h. CAUTION. Do not touch any printed circuit board unless you are wearing a ground wrist strap, as circuit damage may occur. Grounding kits are also available commercially and can be purchased through most electronic wholesalers.

7.4 Environmental Problems

Check to see that none of the following environmental problems exist.

Inadequate Cooling. For 350 A and larger models, allow at least 3 inches of air space (in any direction) between the heat sinks and any item or structure near the PF3 power modules. Heat sink fins should be free of dust or dirt for proper heat transfer, and free of obstructions which could prevent proper airflow.

Contamination. The unit should be periodically cleaned of all dust and dirt. However, certain kinds of dust or particles are particularly conductive. A small accumulation of conductive material can cause component failures from arc-over or complete shorts.

High Ambient Temperature. Lack of a proper ambient-temperature check before installation, or an increase in ambient temperature, can result in numerous problems. Check the ambient temperature under existing conditions. If it is 122 °F (50 °C) or lower, ambient temperature should not be a problem. If it is above 122 °F (50 °C), steps should be taken to provide more cooling, or the PF3 should be moved to a cooler location, or call the Ametek HDR Power Systems service department.

Excessive Vibration. A significant degree of pitched or unpitched vibration can cause numerous problems. If vibration is isolated as a probable cause of improper operation, standard vibration-isolation mounting techniques should be employed.

7.5 Input Power and Load Connections

Turn off the power to the PF3 and check all power connections, input and output, to make sure they are mechanically secure and free of corrosion. Make the same checks at the power source and load. Visually check insulation on input and load wiring for evidence of damage or overheating.

7.6 Correcting Troubles in the PF3 Itself

Table 7.1 provides a comprehensive guide for troubleshooting the PF3.

Table 7.1 Troubleshooting Chart (Symptoms and Solutions)

Cause	Solution
No output even with manual control (Zero) turned full CW.	
(1a) Open SCR fuse	Disconnect power and check the fuse. If it has opened, replace it <u>after</u> completing (b)
(1b) SCRs not firing	Install a good fuse in the circuit, and apply power to the PF3. If the output is fully controllable using the manual control, then resume normal operation. If the power output is still zero, contact Ametek HDR Power Systems service.
Maximum power at all times regardless of control setting.	
(2a) All SCR networks shorted	On units rated above 225 A; Disconnect power and check the front-to-back SCR pairs by measuring resistance between the cathode of the SCR being checked and an unanodized portion of the heat sink. On the Rx1 scale, the resistance should be infinite in both directions. If a shorted component is indicated in any of these checks, replace it. On units rated at 225 A and below: Disconnect power and check the front-to-back SCR pairs by measuring resistance between terminals L1 (of the SCR) and X1. On the Rx1 scale, the resistance should be infinite in both directions. If a shorted component is indicated in any of these cases, replace it.
(2b) Firing control section defective	Return the power to the unit. If the problem persists, contact Ametek HDR Power Systems service.
Output is variable but can't be brought to zero with ZERO control	
(3a) SCR network shorted	Check SCR network per solution 2a.
(3b) Firing control section defective	Contact Ametek HDR Power Systems service for assistance
Output is variable but can't be brought to maximum with SPAN control	
(4a) Firing control section defective	Contact service for assistance

Table 7.2 Torque Specifications

INPUT/OUTPUT CONDUCTOR SIZE, AWG OR CIR. MILS	TORQUE, INCH POUNDS		
	SLOT WIDTH*		HEX HEAD (ALL)
	1/4" OR LESS	OVER 1/4"	
6-4 AWG	25	45	110
2 AWG	35	50	150
1 AWG	40	50	150
1/0 – 2/0 AWG		50	180
3/0 – 4/0 AWG		--	250
250 – 350 MCM		--	325
500 – 700 MCM		--	375
800 – 1000 MCM		--	500

* = Screwdriver Blade Width to Match

(With Socket-Head Screws, all Conductor Sizes)

SOCKET SIZE, ACROSS FLATS	TORQUE INCH POUNDS
3/16"	120
1/4"	200
5/16"	275
3/8"	375
1/2"	500

CHAPTER 8 - Service

8.1 Communication Procedures

If operational problems arise that cannot be resolved by review of all related procedures given in this manual, please contact "Service" at Ametek HDR Power Systems. Please have your model number and serial number of the unit ready as it is required for our technicians to assist you.

NORMAL BUSINESS HOURS 8 am to 5 pm, USA EASTERN TIME ZONE, Monday through Friday.

TELEPHONE 614-308-5500. Our Answering Service will accept your message during all off-hours, including weekends. We receive those messages at 8 am on the next normal workday. We will respond at the earliest time possible, within your time zone and normal work day.

FACSIMILE 614-308-5506. Automatic reception during all hours.

If you are experiencing downtime or other critical circumstances during our off-hours (see above), and wish to telephone us, please inform our Answering Service operator of the nature and degree of your problem. In such cases the operator is authorized to call Ametek HDR Power Systems Service. We cannot, however, guarantee that service assistance will be available at any given off-hour time.

When we are reached by phone, our first step will be to give you over-the-phone assistance at no charge. If the problem cannot be resolved by phone we will arrange for service at your site or by shipment to Ametek HDR Power System, as you request. We will make every possible attempt to support your emergency, on-site needs, regardless of how contacted.

8.2 Spare Parts Orders – Routine or Emergency

Requests for spare parts should be directed to "Inside Sales" at Ametek HDR Power Systems during normal hours, if possible, or via any method shown above for off-hours. Often we can provide same-day delivery for critical circumstances. When contacting us, please present as much information as possible – the related equipment Model Number and Serial Number; the required part name and any identifying part of vendor number(s); and your time needs. An approved Purchase Order Number should be given with your order.

8.3 Spare Parts List

The following table lists the minimum recommended quantities for spare parts for the PF3. As spares are used, replacements should be ordered.

The listed SCR current ratings are the half-wave average values. The calculation for half-wave average value is nameplate current times 0.45.

Table 8.1 PF3 Spare Parts List

Item	Item No.	Qty
60 Ampere Units		
Fuse, 80 A, 700 V	7580070I	3
PCB Assy, PF3 Extended Gate	2099157	1
PCB Assy, DVDT	2099000	3
SCR/dual pkg, 90 A, 1400 V	6791114	3
90 Ampere Units		
Fan, axial, 115 Vac, 110 CFM	4520001	2
Fuse, 125 A, 700 V	7512170I	3
PCB Assy, PF3 Extended Gate	2099157	1
PCB Assy, DVDT	2099000	3
SCR/dual pkg, 90 A, 1400 V	6791114	3
120 Ampere Units		
Fan, axial, 115 Vac, 110 CFM	4520001	2
Fuse, 150 A, 700 V	7515170I	3
PCB Assy, PF3 Extended Gate	2099157	1
PCB Assy, DVDT	2099000	3
SCR/dual pkg, 90 A, 1400 V	6791114	3
180 Ampere Units		
Fan, axial, 115 Vac, 110 CFM	4520001	2
Fuse, 225 A, 700 V	7523170I	3
PCB Assy, PF3 Extended Gate	2099157	1
PCB Assy, DVDT	2099000	3
SCR/dual pkg, 142 A, 1400 V	6712114	3
225 Ampere Units		
Fan, axial, 115 Vac, 110 CFM	4520001	2
Fuse, 300 A, 700 V	7530170I	3
PCB Assy, PF3 Extended Gate	2099157	1
PCB Assy, SCR, DVDT	2099000	3
SCR/dual pkg, 162 A, 1400 V	6722114	3
350 Ampere Units		
Fan, axial, 115 Vac, 110 CFM	4520001	3
Fuse, 450 A, 700 V	7500123	3
Lug Kit, 2/3 Phase 350 A	2710208	3
PCB Assy, PF3 Extended Gate	2099157	1
SCR, 600 A, 1400 V	5060114	6
PCB Assy, DVDT	2071000	3
500 Ampere Units		
Fan, axial, 115 Vac, 100 CFM	4520001	3
Fuse, 630 A, 700 V	7500124	3
Lug Kit, 2/3 Phase 500 A	2710209	1
PCB Assy, PF3 Extended Gate	2099157	1
SCR, 800 A, 1400 V	5080114	6
PCB Assy, DVDT	2071000	3

Item	Item No.	Qty
650 Ampere Units		
Fan, axial, 115 Vac, 350 CFM	4520002	3
Fuse, 800 A, 700 V	7500125	3
Lug Kit, 2/3 Phase 650 A	2710210	1
PCB Assy, PF3 Extended Gate	2099157	1
SCR, 1500 A, 1400 V	5015214	6
PCB Assy, DVDT	2072000	3
800 Ampere Units		
Fan, axial, 115 Vac, 350 CFM	4520002	3
Fuse, 1000 A, 700 V	7500126	3
Lug Kit, 2/3 Phase 800 A	2710211	1
PCB Assy, PF3 Extended Gate	2099157	1
SCR, 1500 A, 1400 V	5015214	6
PCB Assy, DVDT	2072000	3
1000 Ampere Units		
Fan, axial, 115 Vac, 350 CFM	4520002	3
Fuse, 1250 A, 700 V	7500127	3
Lug Kit, 2/3 Phase 1000 A	2710212	1
PCB Assy, PF3 Extended Gate	2099157	1
SCR, 2800 A, 1400 V	5028214	6
PCB Assy, DVDT	2072000	3
1200 Ampere Units		
Fan, axial, 115 Vac, 350 CFM	4520002	3
Fuse, 1600 A, 700 V	7500128	3
Lug Kit, 2/3 Phase 1200 A	2710213	1
PCB Assy, PF3 Extended Gate	2099157	1
SCR, 2800 A, 1400 V	5028214	6
PCB Assy, DVDT	2072000	3

8.4 Drawing List

This Chapter contains drawings that show outline dimensions, installation wiring, and printed circuit board component locations, as well as an overall schematic of the PF3. These drawings are useful in installing and troubleshooting all PF3 models. Table 8.2 lists the drawings for each model, Appendix provides simplified drawings in the order of their appearance. Drawings may also be downloaded from www.hdrpower.com.

Table 8.2 PF3 Drawing List

Drawing Title	Drawing No.
Schematic, PF3 – 60 - 1200 A	S2710063
Outline & Mounting, PF3 – 60 - 225 A	M2710038
Outline & Mounting, PF3 – 350 A, 500 A	M2710042
Outline & Mounting, PF3 – 650 A	M2710044
Outline & Mounting, PF3 – 800, 1000, 1200 A	M2710045

CHAPTER 9 – Warranty Policy

This chapter details the warranty policy of Ametek HDR Power Systems products. Ametek HDR Power Systems standard warranty policy is listed below. Note that the warranty policy for a particular job agreement may be different from the standard policy. When in doubt about warranty information, consult the factory.

9.1 Warranty

WARRANTY

AMETEK HDR warrants that the equipment delivered will be free from defects in workmanship and material for a period of five years from the date of shipment. AMETEK HDR will repair or replace, at AMETEK HDR's option, any part found defective during proper and normal use, provided that written notice of the nature of the defect is received by AMETEK HDR within the five year warranty period and that the customer returns the part to AMETEK HDR freight paid both ways. This warranty is not transferable by the initial end user.

AMETEK HDR MAKES NO OTHER WARRANTIES, EXPRESSED OR IMPLIED (INCLUDING, WITHOUT LIMITATION, MERCHANTABILITY, FITNESS FOR PURPOSE, OR AGAINST INFRINGEMENT OF ANY PATENT) EXCEPT AS EXPRESSLY PROVIDED HEREIN.

THE REMEDY OF REPAIR OR REPLACEMENT IS CUSTOMER'S SOLE AND EXCLUSIVE REMEDY AND WILL SATISFY ALL OF AMETEK HDR'S LIABILITIES, WHETHER BASED ON CONTRACT, NEGLIGENCE, TORT, PRODUCT LIABILITY, STRICT LIABILITY, OR OTHERWISE. IN NO EVENT WILL AMETEK HDR BE LIABLE FOR INCIDENT OR CONSEQUENTIAL DAMAGES, NOR IN ANY EVENT SHALL HDR'S LIABILITY EXCEED THE UNIT PRICE OF ANY DEFECTIVE PRODUCT OR PART.

9.2 In-house Repair Services

For all repair service at Ametek HDR Power Systems, you will need a Repair Material Authorization (RMA) number. Call **(614) 308-5500** and request a Repair Material Authorization (RMA) number. Please reference this number when making inquiries. Use the shipping address below for returns:

Ametek HDR Power Systems
503 Lakeview Plaza Blvd, Ste C
Worthington, Ohio, 43085
Attention: Repair Department/RMA #()

Prepay the shipment and include the following information if you are not using an Ametek HDR Power Systems Return Repair Tag: the Repair Material Authorization (RMA) number, part number, a description of the problem, contact phone number, a technical contact phone number (if different) and any additional comments. Put the Repair Material Authorization (RMA) number on the label.

Warranty Repairs: In addition to securing Repair Material Authorization (RMA) number, please supply the **System Serial number** (found on the system, usually on the tag inside the cabinet door).

Non-Warranty Repairs: Secure a Repair Material Authorization (RMA) number from Ametek HDR Power Systems. The price for exchange or repair will be quoted when the unit can be evaluated. Once determined a quote will be provide, please include your hard copy purchase order (PO) for this amount, or fax your PO directly to the Sales Department at (614) 308-5506. Expedited services are available upon request.

9.3 Field Service Repairs

Repairs may be performed at your location. Please contact Ametek HDR Power Systems at (614) 308-5500 to discuss terms and conditions, to get the current service rates and to schedule field repairs at your location.

Appendix B – 60-225 A Outline

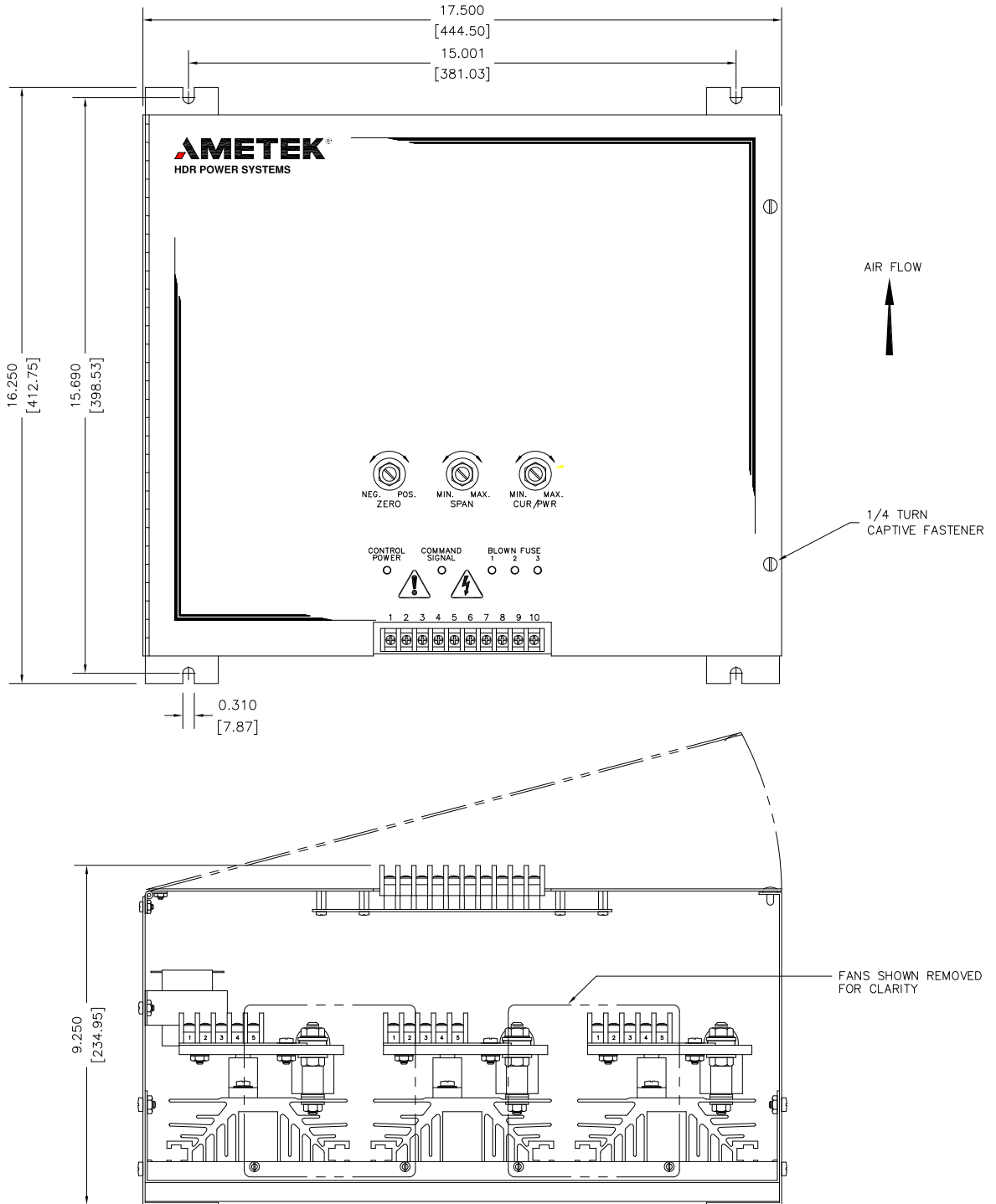

Appendix C – 350-500 A Outline



Appendix D – 650 A Outline

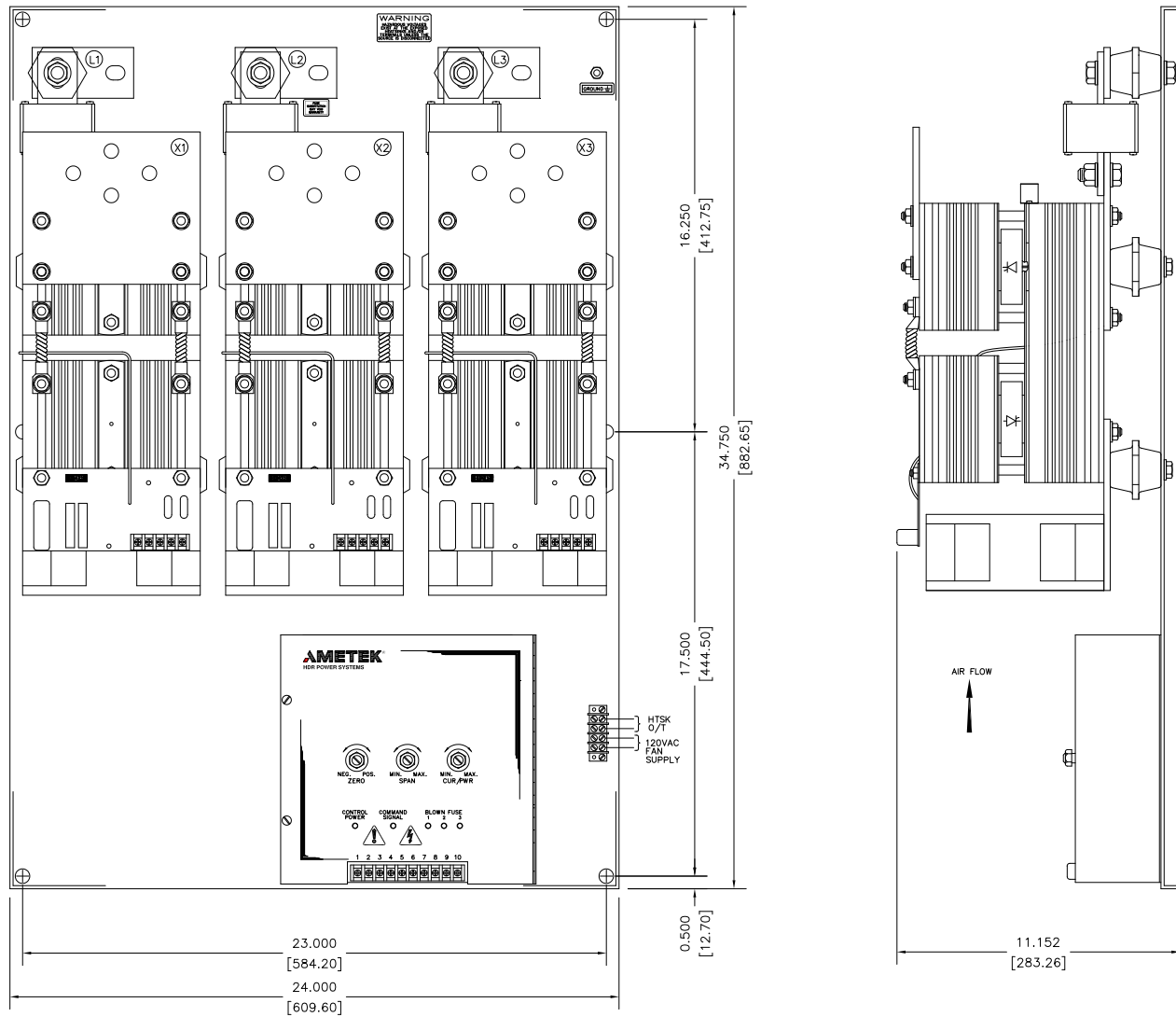

Appendix E – 800-1200 A Outline

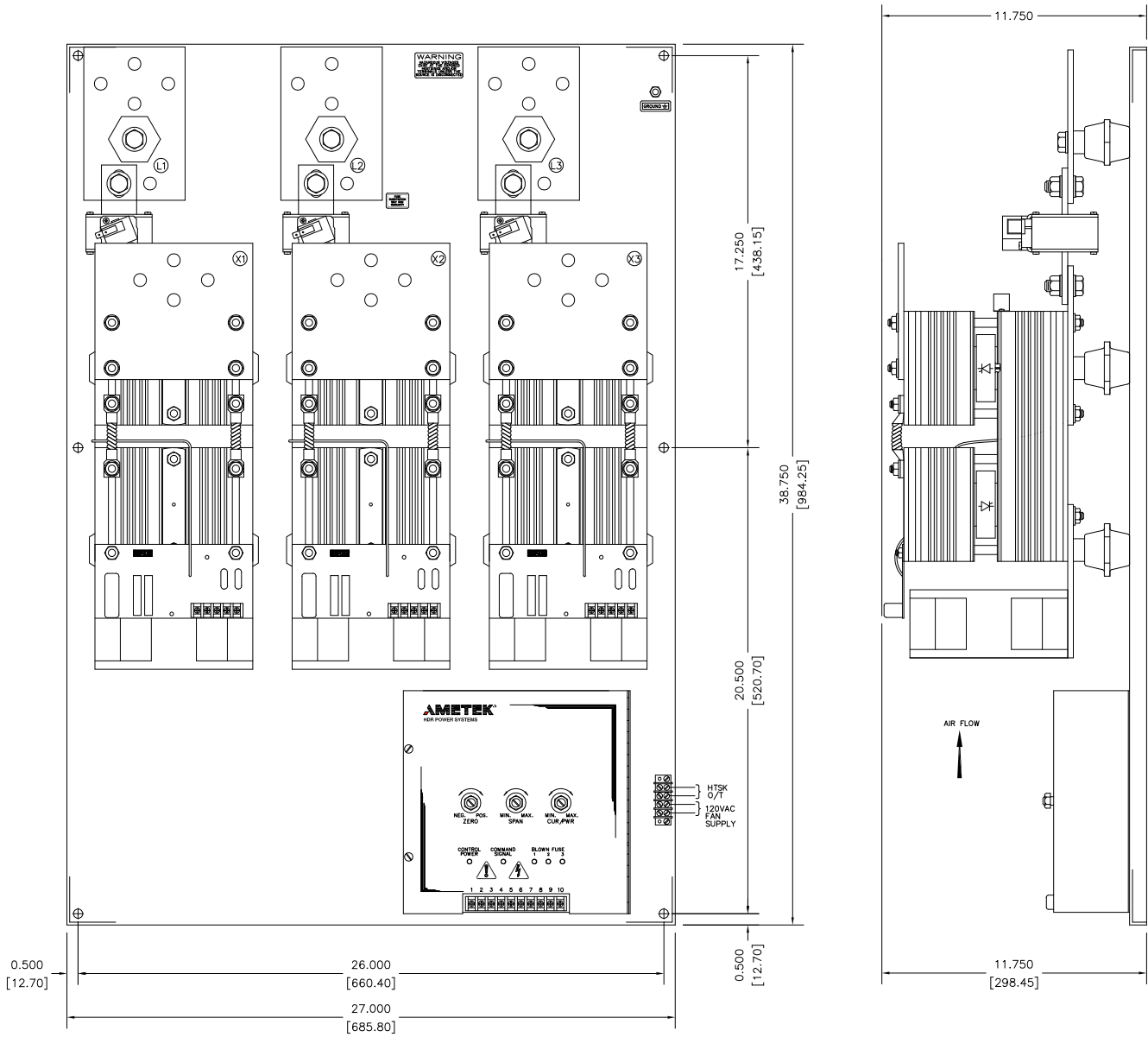

Appendix F – Declaration of Conformity



EC DECLARATION OF CONFORMITY

WE: **AMETEK HDR POWER SYSTEMS**
503 Lakeview Plaza Blvd, Ste C
Worthington, Ohio, 43085 - USA

Declare under our sole responsibility that the products listed below and bearing the CE label:

Type: SCR power controllers with the following model designations and current ratings:

ZF1, ZF2, ZF3, PF1, PF3 - 15, 25, 40, 60, 70, 90, 120,
180, 225, 350, 500, 650, 800, 1000 and 1200A.
SHZF1, SHPF1 - 15, 30, 40, 60, 70, 90 and 120A
SHZF2, SHZF3, SHPF3 - 15, 25, 30, 60, 90, 120, 180 and 225A
SCZF1, SCPF1 - 15, 25, 40 and 65A
All applicable options

To which this declaration relates is in conformity with the technical requirements of the following documents:

Title: Low-voltage switchgear and control gear	No. IEC 947-5-1 Year: 1990-03
Low Voltage Directive	No. IEC 73/23/EEC Year: 1973-02
Degrees of protection provided by enclosures (IP Code):	No. IEC 529-2nd Edition Year: 1989-11
Electromagnetic Compatibility	No. IEC89/336/EEC Year: 1989-05

Warning
All phase-fired (PF) controllers will require line filters and possibly shielded cables to meet the EMC requirements.

(Environmental protection classification IP00 - for mounting inside an enclosure)

Note: Characteristics are according to mfg specifications.

Name: Steve Wetta

Title: Director of Engineering

Date: July 21, 2015

Signature:

Declaration written in accordance with I.S.O. - IEC/22 Guide

Note: Certification performed on November 9, 2000 and revision is address change only

Notes:



503 Lakeview Plaza Blvd, Ste C
Worthington, Ohio, 43085 USA