

APPLICATION NOTE - 1004

Topic: WATER AS AN ALTERNATE METHOD
FOR COOLING HIGH POWER ELECTRONIC EQUIPMENT

Author - George A. Sites, VP AMETEK HDR Power Systems

INTRODUCTION

Have you ever had equipment failures due to dirty air filters, high ambient temperatures or "Burned Out" exhaust fans? Did you ever wish you could seal your equipment enclosure and keep it clean from the day to day dirt, dust and grime in your plant? If so, then water-cooling may be the answer you've been looking for!

Water has been used for many years as the most efficient method for transferring electrical power losses in the form of heat generated by the equipment. Water, as a cooling agent is a more effective heat transfer agent than air.

Although water-cooling has a few disadvantages, the advantages still make it an excellent choice especially for troubled installations. Keep in mind that the life of power electronic equipment is directly affected by it's operating temperature. Keep it cool and it should last a long time.

SELECTION CRITERIA

The following questions will assist you in deciding whether water-cooling makes sense for your application.

1. *Is the installation site contaminated with dirt, dust or grime, especially conductive dust?*
2. *Do you have frequent electronic equipment failures due to heat related problems?*
3. *Is cooling water available?*
4. *Does your plant have a high ambient temperature?*
5. *Would a smaller overall size help?*

If your answer is yes to most of the preceding questions, then water-cooling will most likely help your situation.

AMETEK HDR POWER SYSTEMS 3563 Interchange Rd. Columbus, OH 43204
Telephone 614-308-5500 Fax 614-308-5506

1-888-797-2685

ADVANTAGES/DISADVANTAGES

First of all, the most obvious advantage is equipment with a lower operating temperature - lower temperatures in electronic equipment normally means higher reliability.

Sealed enclosures are common in water cooled equipment since the heat generated from the power losses are removed via the cooling water through air-to-water heat exchangers, chill blocks and in the case of transformers - the actual winding can be a hollow tube with water flowing through it.

If the overall size is important (and it almost always is) the enclosure can be made smaller because the individual components are usually smaller. In some cases, the overall equipment size can be reduced by 30% or more.

Water flow requirements are not as great as you would expect! Generally speaking, .25 GPM of water will dissipate 1 kilowatt of heat and only have a 15 C temperature rise in the water. However each piece of equipment is different and the water requirements should be reviewed.

The disadvantages are simply the initial cost of the equipment and plumbing plus the cost of cooling water, which is minimal especially in a closed loop system.

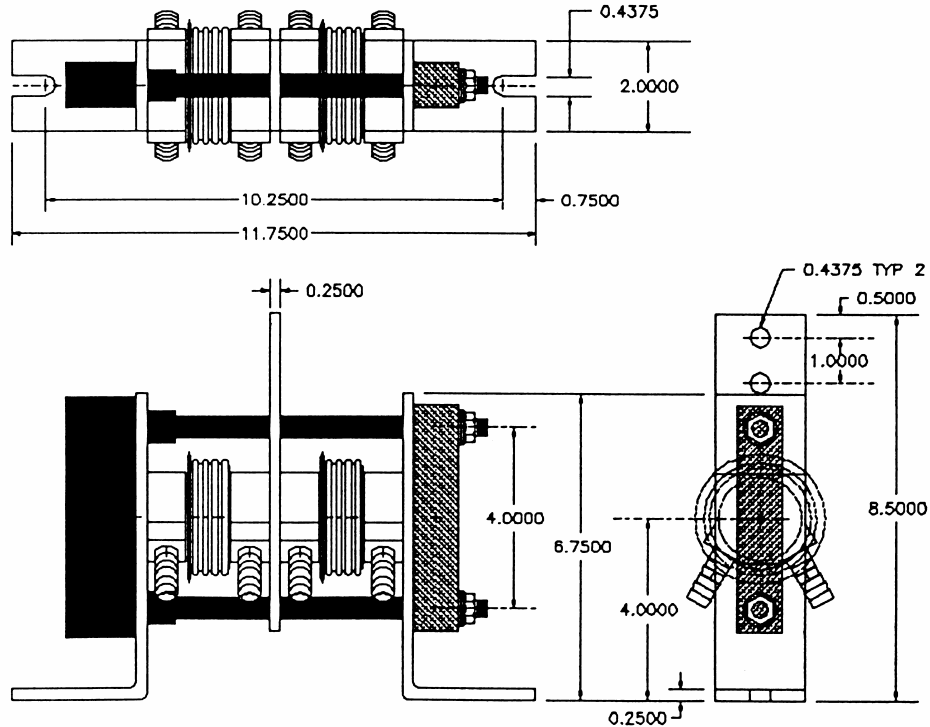

A typical dual SCR water-cooled chill block assembly.
(Drawing courtesy of Value Engineered Products)

WATER CONTAMINANTS

Consider the following contaminants as possible problems.

HARDNESS - when water is subjected to high temperatures and it contains high levels of magnesium and calcium salts, some of these salts may be deposited as scale on the inside of water passages which could restrict flow and decrease heat transfer. Also, a high concentration of these ions will increase the conductivity of the water.

SUSPENDED SOLIDS - these are solids that are insoluble, but remain in suspension due to turbulence of the water. These can cause clogging and reduce heat transfer. These are simply removed by filtration.

ACIDITY - you may encounter water that contains a large amount of free mineral acids. This causes the water to become quite corrosive. This condition needs to be neutralized as soon as possible.

ALKALINITY - this is one of the main contributors of calcium carbonate as scale in a water system. The higher the alkalinity, the higher the chance for scale to form. Treat the water as soon as possible when this occurs.

SLIME & ALGAE - these biological growths can cause clogging and loss of heat transfer. This growth can cause differential oxygen concentration cells that cause serious pitting of the interior walls of the water passages.

WATER REQUIREMENTS

All is not as bad as it seems. Simply put, if the water is of drinking quality then it is safe to cool electronic equipment.

For a more detailed description of the water consider the following specifications as ideal maximum levels.

WATER CHARACTERISTICS

- Total Hardness of CaCO₃ - 100ppm
- Total Dissolved Solids - 200ppm
- Conductivity - to be within the range of 60 to 300 micro mhos/cm
- pH - 7.0 to 8.0
- Suspended Solids - 10ppm
- Chloride - less than 200ppm
- Sulfate - less than 250ppm
- Chromate's - less than 50ppm
- Iron (Ferric or Ferrous) - not to exceed 1ppm

WATER SYSTEM CHARACTERISTICS

- Maximum inlet water temperature of 102°F (40°C)
- Minimum inlet water temperature above the dew point to avoid condensation
- Maximum pressure of 80 PSIG limited at the inlet to the equipment
- Water flow is per the equipment specification

Corrosion or oxidation can be caused by dissolved oxygen in the water. This oxidation is a very good thermal barrier that can reduce the effective cooling of the water system. Chemical inhibitors may be added to the water to reduce the dissolved oxygen but be careful, these chemicals will reduce the resistivity of the water. Always monitor the water resistivity/conductivity after adding any chemicals.

ENVIRONMENTAL

As you know in recent years, we have become increasingly aware of the need to conserve water and to take precautions to prevent contamination of our rivers and streams.

Please be kind to your equipment and the environment by utilizing a safe, properly maintained water system.

CONCLUSION

By using a properly installed, maintained and sized water system you can prolong the life of your electrical equipment and be kind to our environment at the same time.



A typical closed-loop water system.
(Photo courtesy of Water Saver Systems, Inc.)